



FOAM, GLUE, TAPE AND A LITTLE IMAGINATION....



(Version 1.0 Shown In Picture )

*(RC Model Airplane Construction Plans)*

# **rcFoamFighters**

## **FB-28 (Fighter Bomber 28)**

*Basic Template*

*(Design by Frank Petty - Nov. 2008 - Rev 1.1)*

*(CAD Drawing by Paul Petty - Oct. 2009)*

**FREE PLAN - NOT TO BE SOLD**

# rcFoamFighters

FB-28 (Fighter Bomber 28)

## Basic Template

(Design by Frank Petty - Nov. 2008 - Rev 1.1)

(CAD Drawing by Paul Petty - Oct. 2009)

(Basic Template Release 1.1 - Copyright rcFoamFighters)

(Contact rcFoamFighters at: [admin@rcfoamfighters.com](mailto:admin@rcfoamfighters.com))

(Please Visit Our Blog at: <http://rcfoamfighters.com/blog/>)

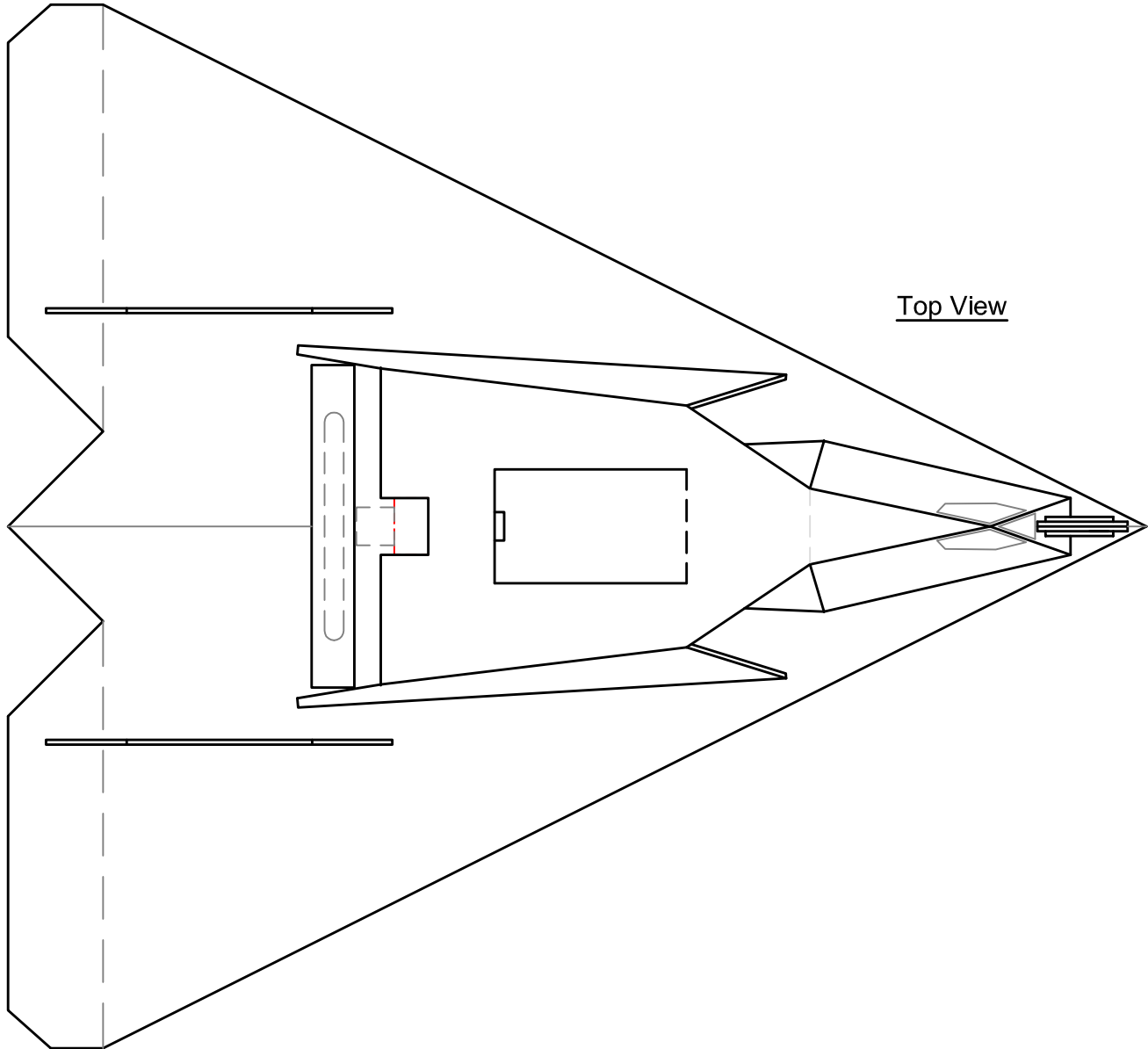

Top View

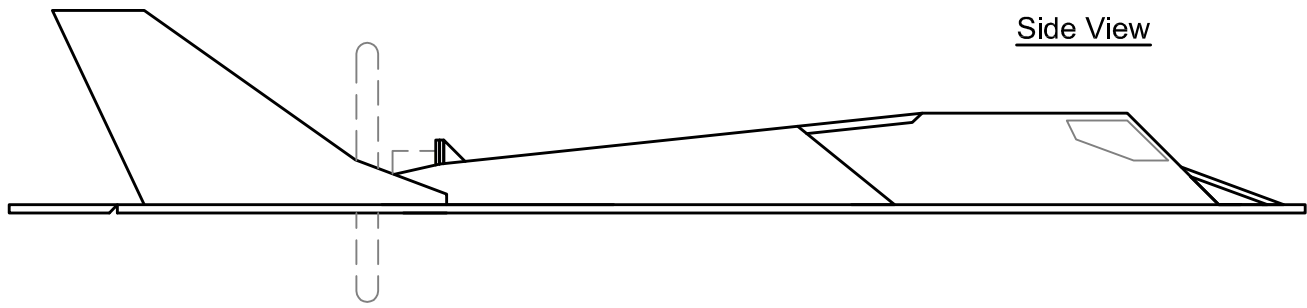

Side View

**Recommend Parts:**

BASIC SETUP (58+mph)

Motor: Suppo A2212/6 2200kV Brushless Motor  
ESC: Suppo 30A Brushless ESC  
Prop: APC 6x4  
Battery: 2200mA (25C or better recommended)  
Servos: 2 Each Micro Metal Gear  
Radio & Receiver: Any 6-channel or better (2.4ghz preferred)

PERFORMANCE SETUP (70+mph)

Motor: Grayson Hobbies "Super Mega Jet" 2550kV Motor  
ESC: 40A Brushless ESC  
Prop: APC 6x5.5  
Battery: 2200mA (30C recommended)  
Servos: 2 Each Micro Metal Gear  
Radio & Receiver: Any 6-channel or better (2.4ghz preferred)

Plane was originally designed to be made from 2 Sheets of 20x30 Foamboard.

Depron or FanFold Foam with Carbon Spars may be used .

**Disclaimer (Please Read):**

- This is a design template for a high performance, high speed RC aircraft. This plane should only be built and flown by experienced pilots with adequate skill to fly fast, maneuverable planes.
- DO NOT fly this plane where it can endanger people, livestock or property.
- ANY PERSONS DECIDING TO BUILD AND FLY THIS PLANE DOES SO AT HIS/HER OWN RISK. RCFOAMFIGHTERS ASSUMES NO RESPONSIBILITY FOR THE PERFORMANCE OF THIS PLANE.
- This plane should only be launched via the side launch method. Do not attempt to launch from the top or bottom of the fuselage. Doing so can cause bodily harm if any hand or body part comes into contact with the fast spinning propeller.
- All minors should fly under the supervision of an adult or guardian.

**SCRATCH BUILT BASSWOOD MOTOR MOUNT  
(MADE FROM 3/32" BASSWOOD SHEETS)**

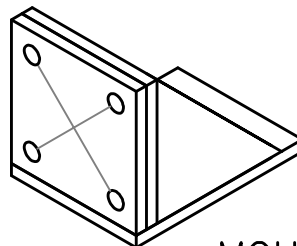
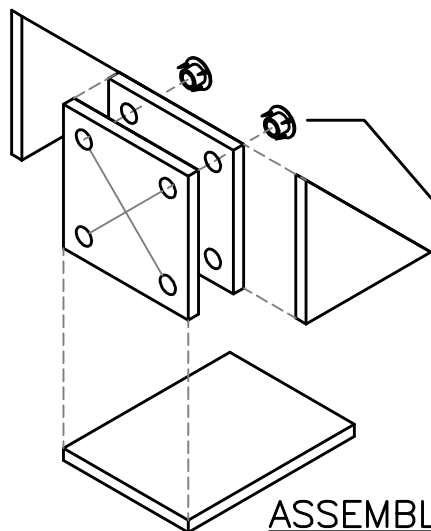

MOUNT

INSERT 4 EACH, 4-40 BLIND NUTS INTO BACK OF MOTOR MOUNT PLATE. INSURE HOLE PATTERN IS DRILLED TO MATCH MOTOR TO BE USED. (USE 4 EACH 4-40 HEX BOLTS TO SECURE MOTOR TO MOUNT.)

ASSEMBLE

1EA. 1.5"X2" RECTANGLE

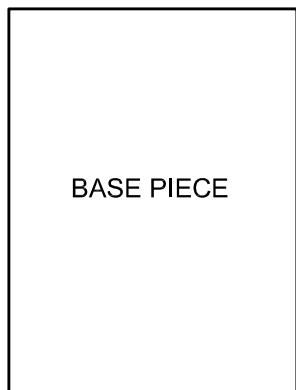

3EA. 1.5"X1.5" SQUARES

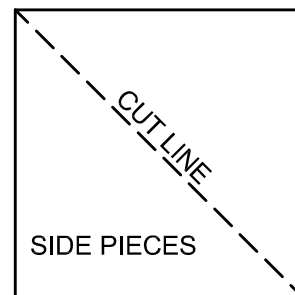
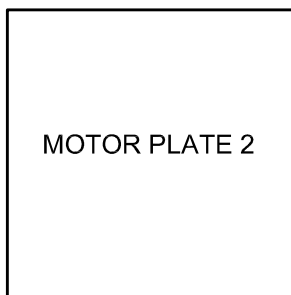
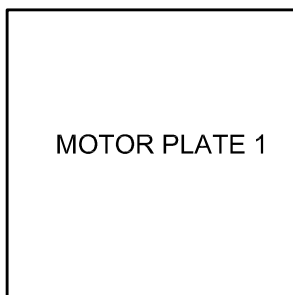

# FOAMBOARD BATTERY BOX TEMPLATE (VERIFY WITH SIZE OF BATTERY TO BE USED)

BATTERY BOX  
(Isometric View)

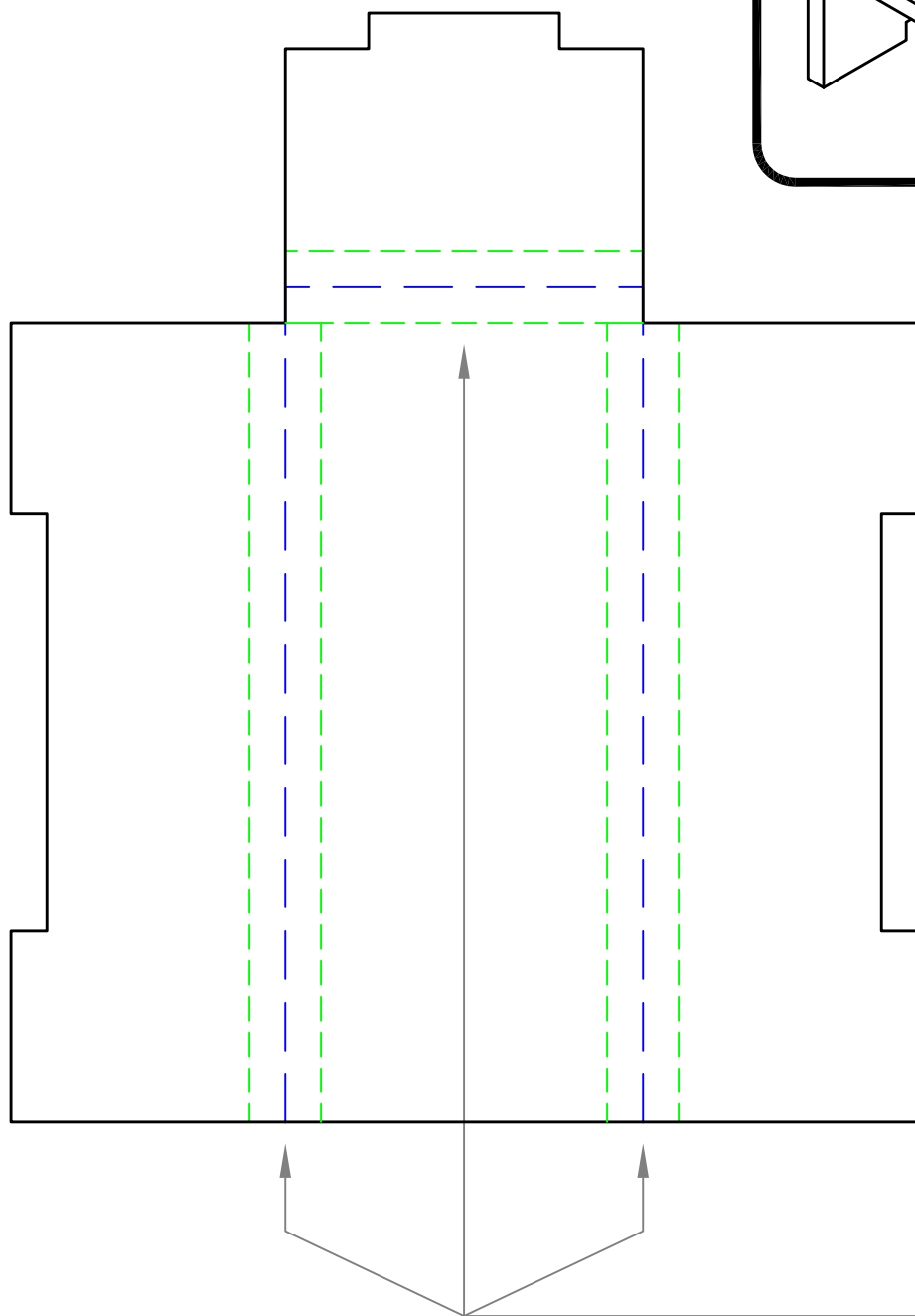
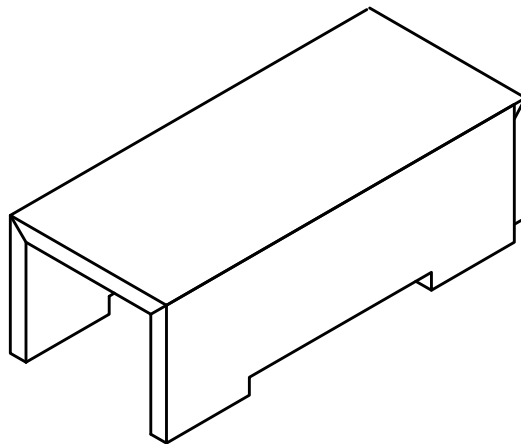

Example of Double  
45° Bevel Cut.

(Side View)



(Isometric View)

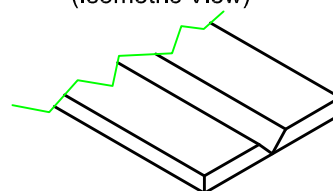

# TEMPLATE ASSEMBLY KEY PLAN

## rcFoamFighters

### FB-28 (Fighter Bomber 28)

(Design by Frank Petty - Nov 2008 - Rev 1.1)

(CAD Drawing by Paul Petty - Oct. 2009)

#### INSTRUCTIONS:

PRINT ALL TEMPLATE SHEETS. CUT AND ASSEMBLE AS SHOWN BELOW. USE SCOTCH TAPE TO SECURE SHEETS TOGETHER.

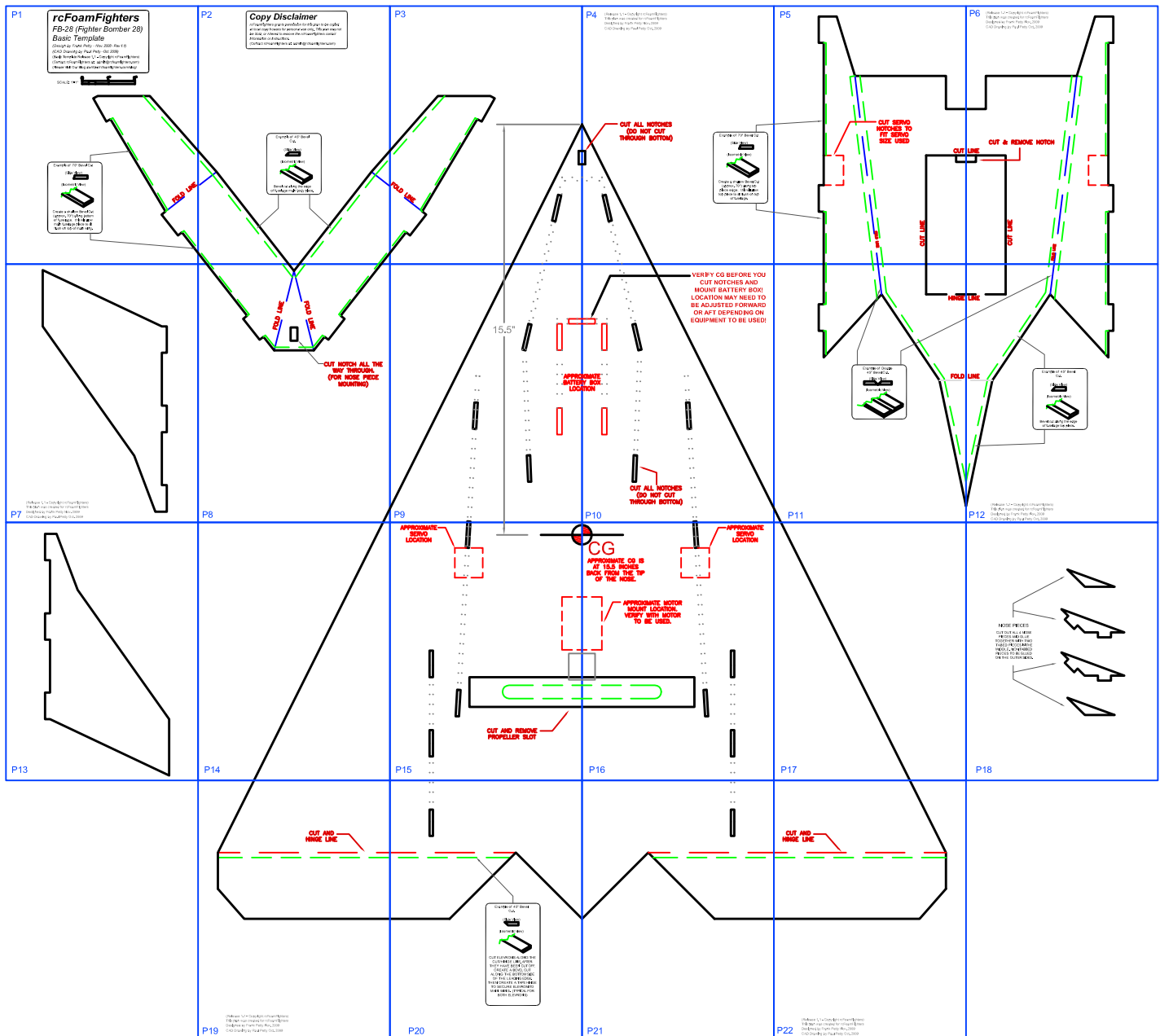

P1

# rcFoamFighters

FB-28 (Fighter Bomber 28)

## Basic Template

(Design by Frank Petty - Nov. 2008 - Rev 1.1)

(CAD Drawing by Paul Petty - Oct. 2009)

(Basic Template Release 1.1 - Copyright rcFoamFighters)

(Contact rcFoamFighters at: [admin@rcfoamfighters.com](mailto:admin@rcfoamfighters.com))

(Please Visit Our Blog at: <http://rcfoamfighters.com/blog/>)

SCALE: 1"=1" 

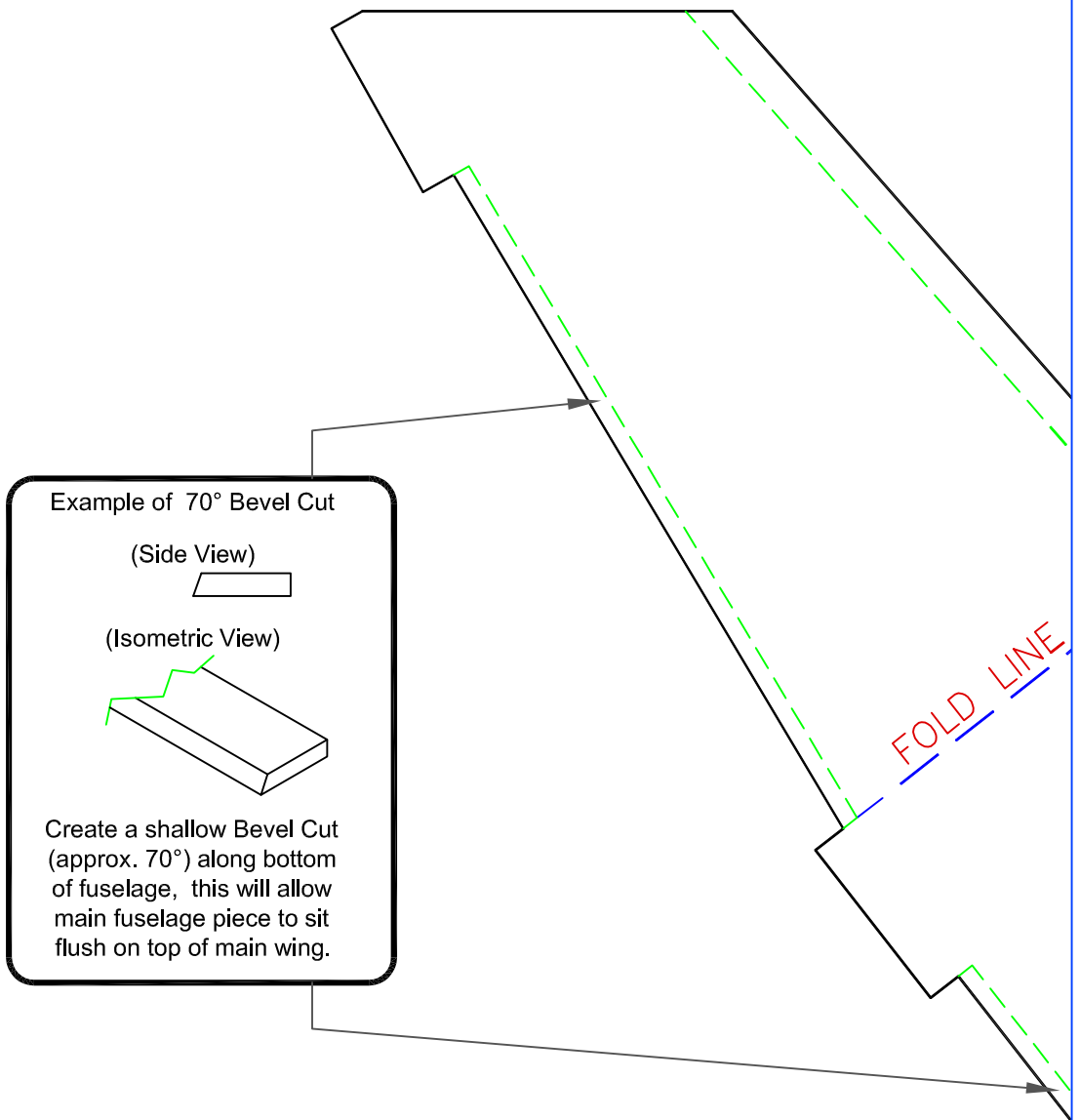

## Copy Disclaimer

*rcFoamFighters grants permission for this plan to be copied at local copy houses for personal use only. This plan may not be Sold, or Altered to remove the rcFoamFighters contact information or instructions.*

(Contact rcFoamFighters at: [admin@rcfoamfighters.com](mailto:admin@rcfoamfighters.com))

Example of 45° Bevel Cut.

(Side View)



(Isometric View)

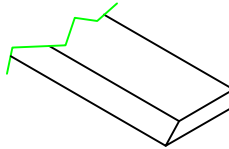

Bevel cut along the edge of fuselage main body piece.

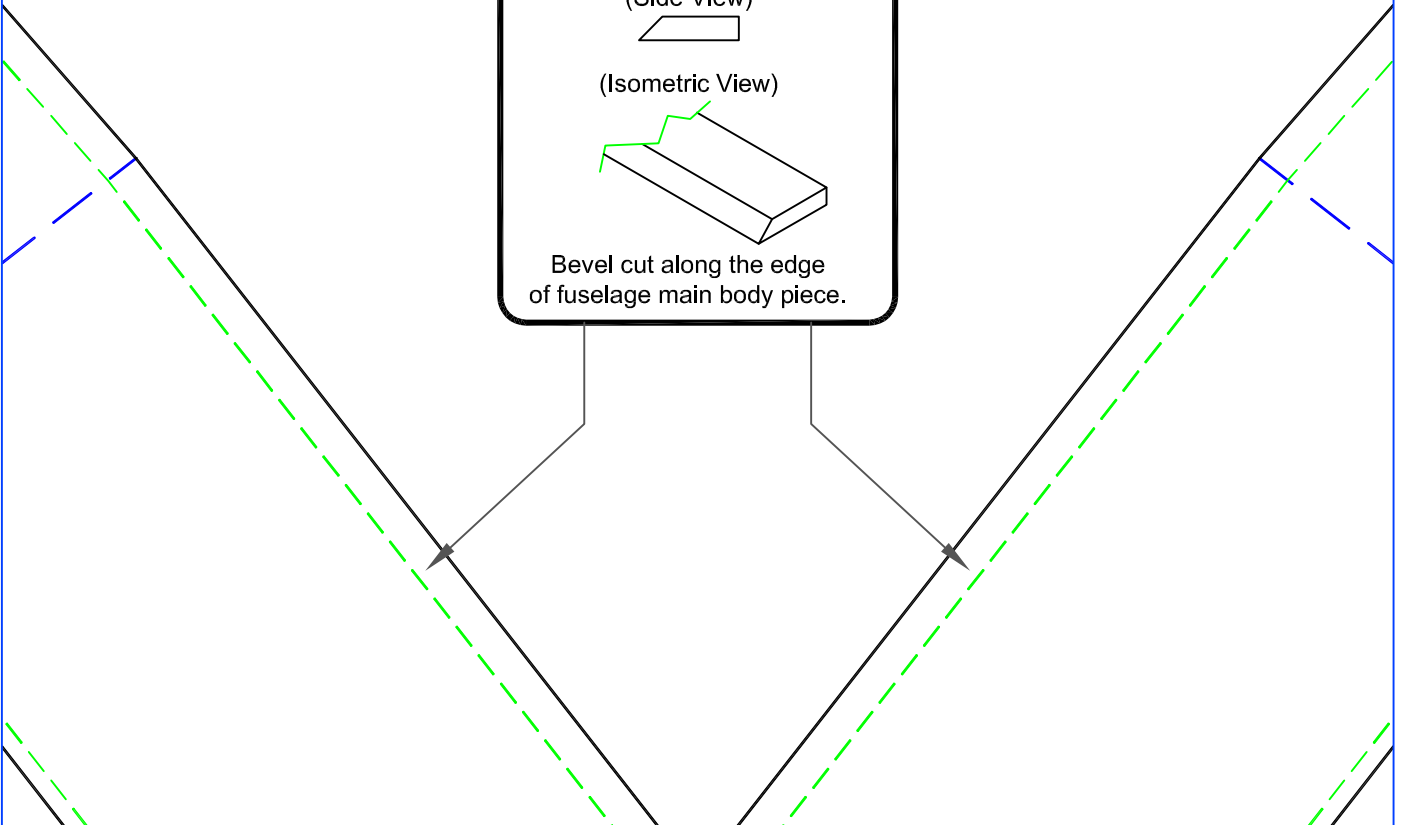

P3

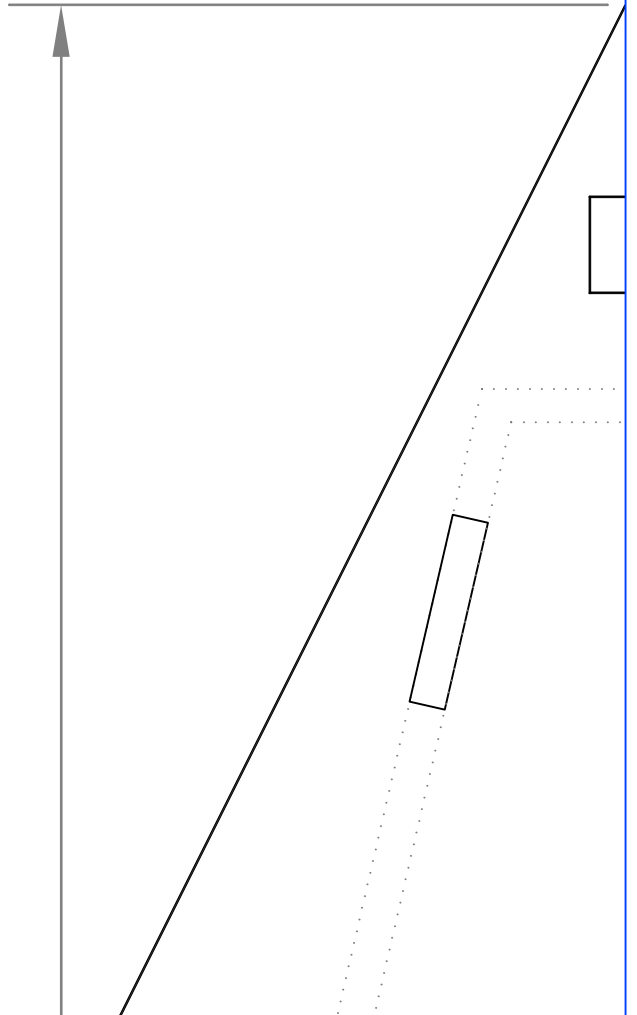
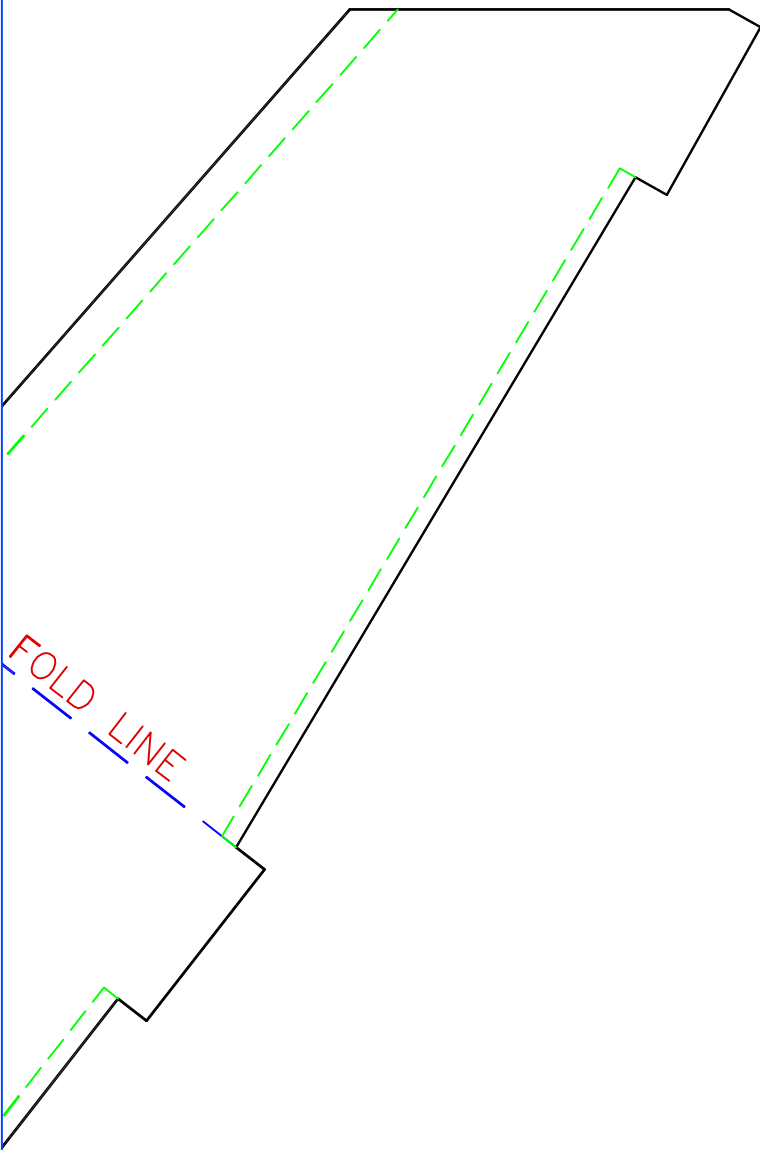

P4

(Release 1.1 - Copyright rcFoamFighters)  
This plan was created for rcFoamFighters  
Designed by Frank Petty Nov. 2009  
CAD Drawing by Paul Petty Oct. 2009

CUT ALL NOTCHES  
(DO NOT CUT  
THROUGH BOTTOM)

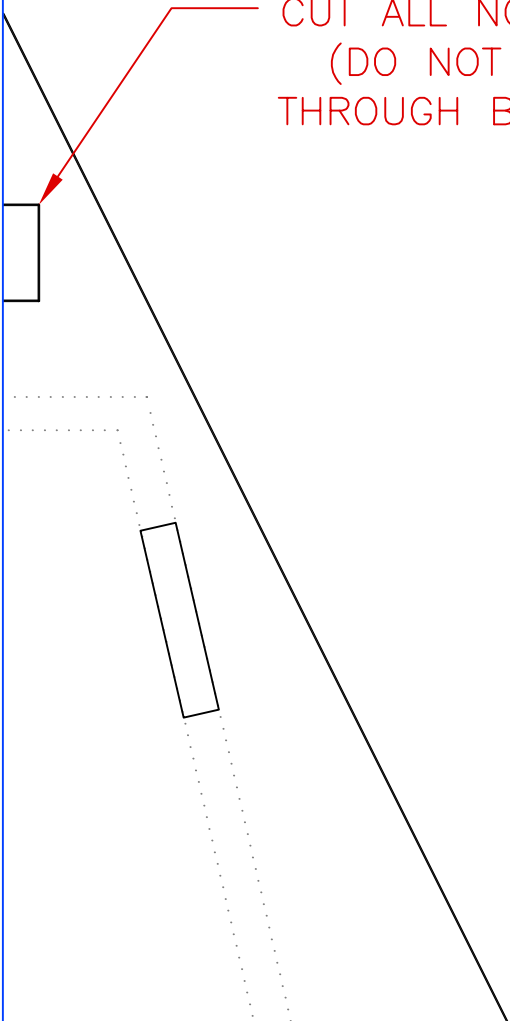

Example of 70° Bevel Cut

(Side View)

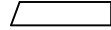

(Isometric View)

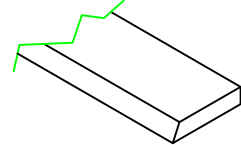

Create a shallow Bevel Cut  
(approx. 70°) along top  
piece edge, this will allow  
top piece to sit flush on top  
of fuselage.

P5

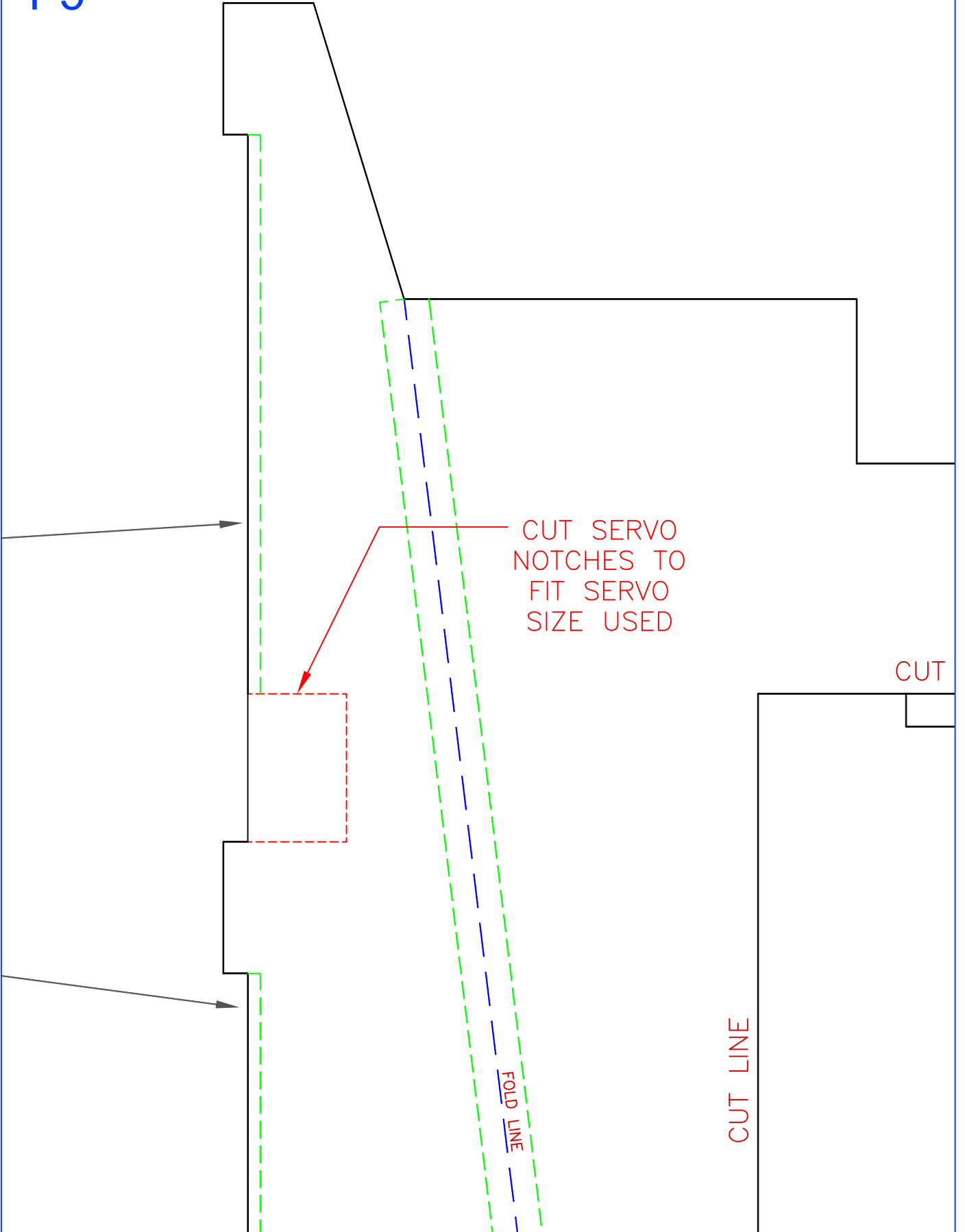

P6

(Release 1.1 - Copyright rcFoamFighters)  
This plan was created for rcFoamFighters  
Designed by Frank Petty Nov. 2009  
CAD Drawing by Paul Petty Oct. 2009

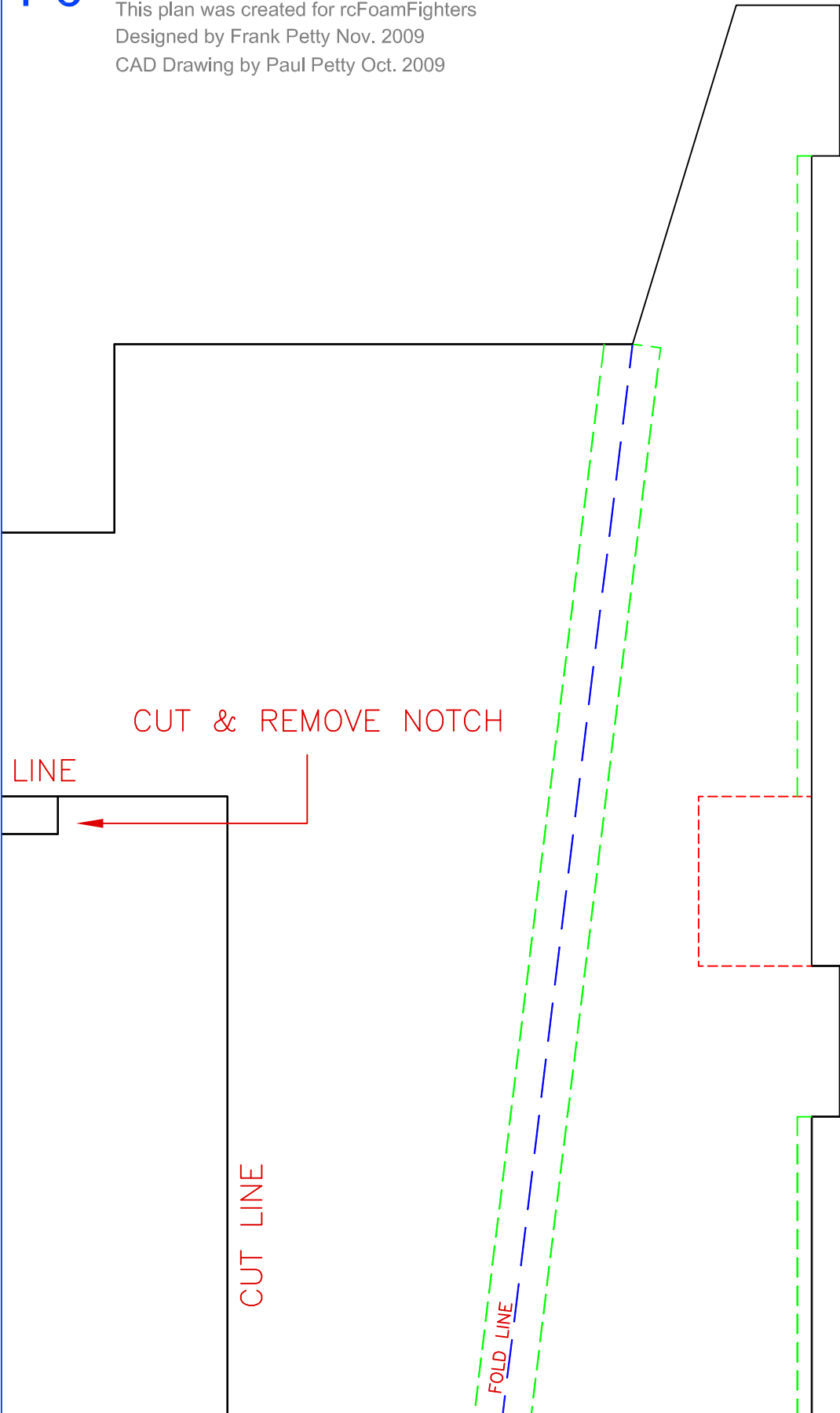

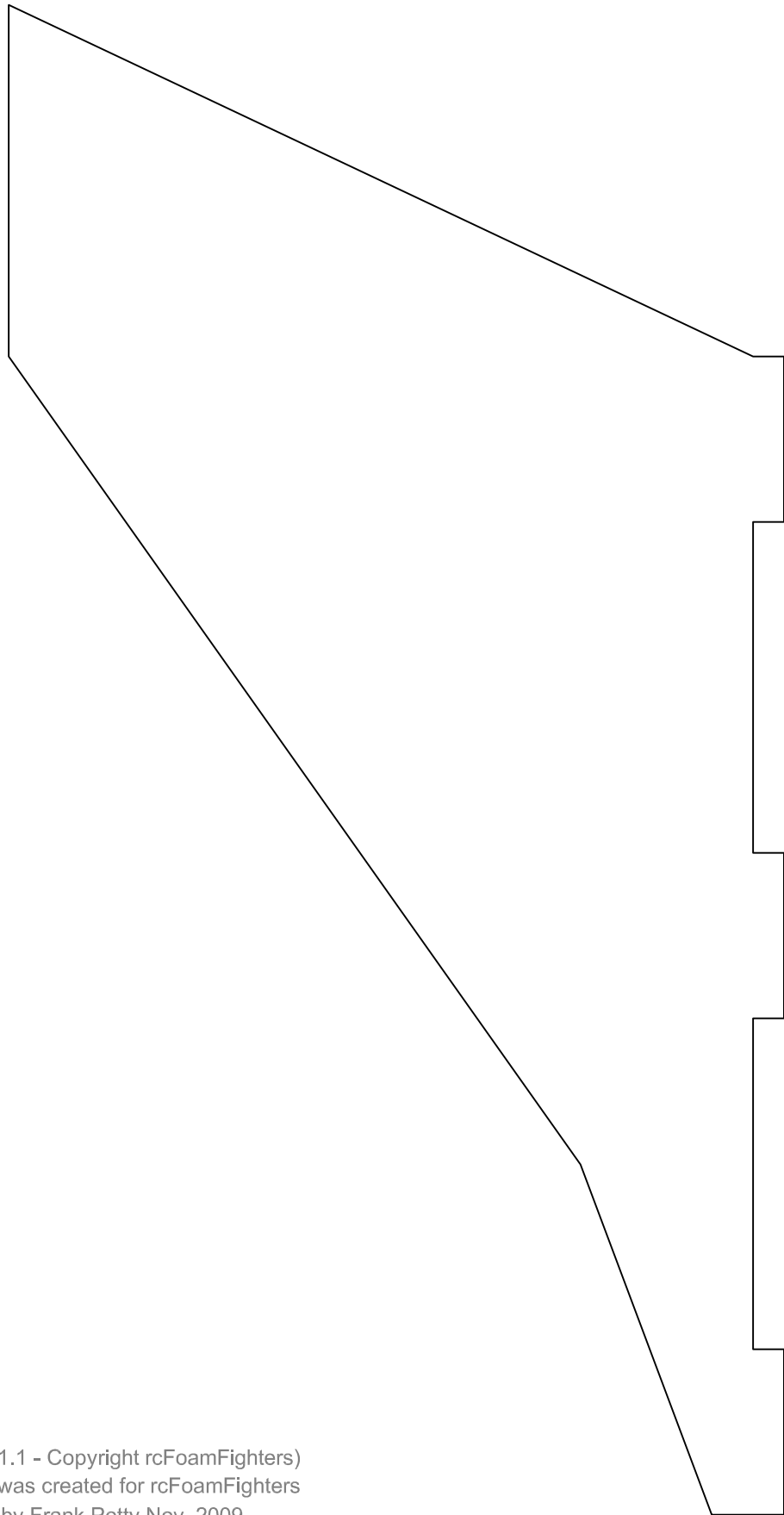

(Release 1.1 - Copyright rcFoamFighters)  
This plan was created for rcFoamFighters  
Designed by Frank Petty Nov. 2009  
CAD Drawing by Paul Petty Oct. 2009

**P7**

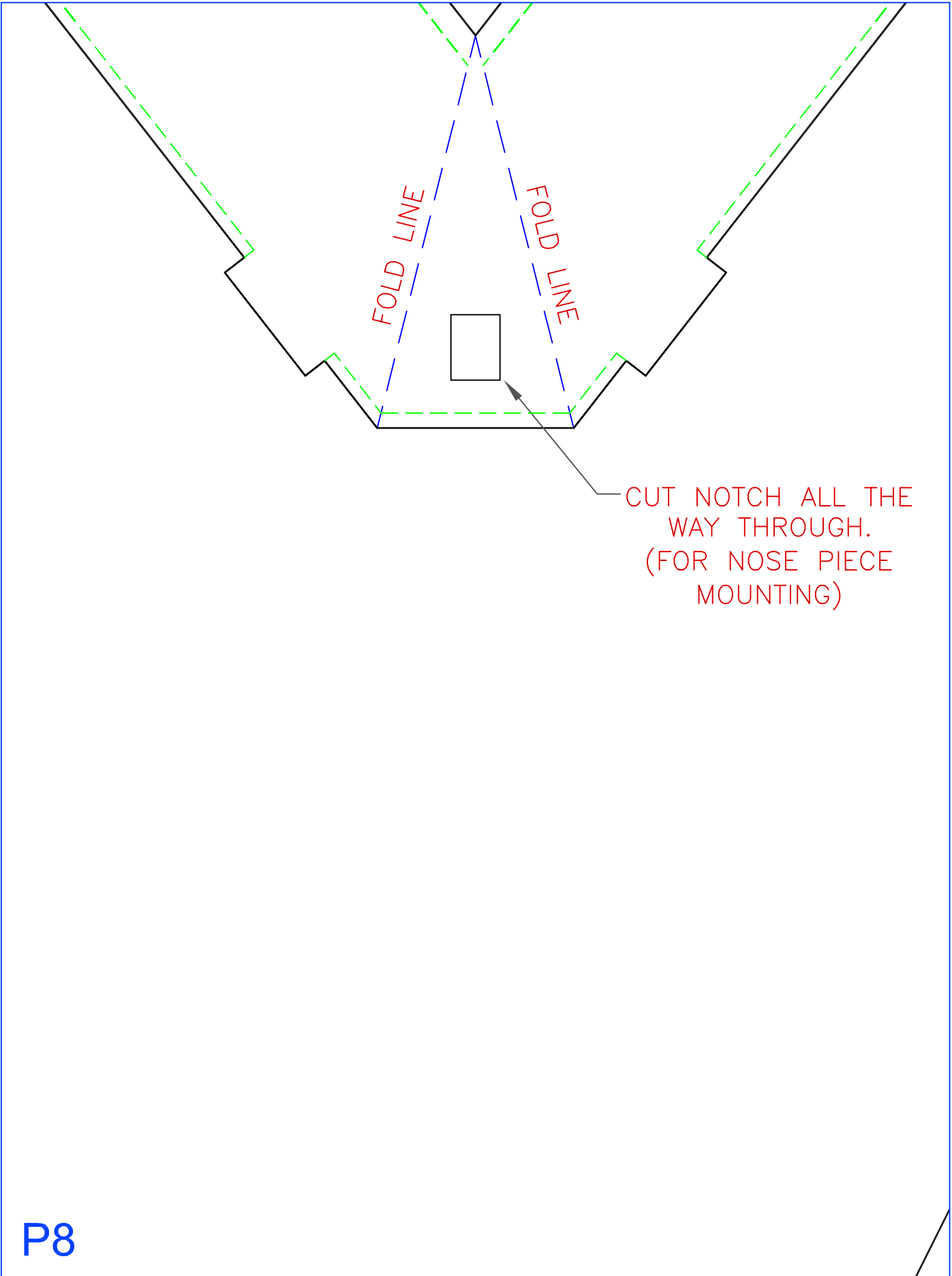

FOLD LINE

FOLD LINE

CUT NOTCH ALL THE WAY THROUGH.  
(FOR NOSE PIECE MOUNTING)

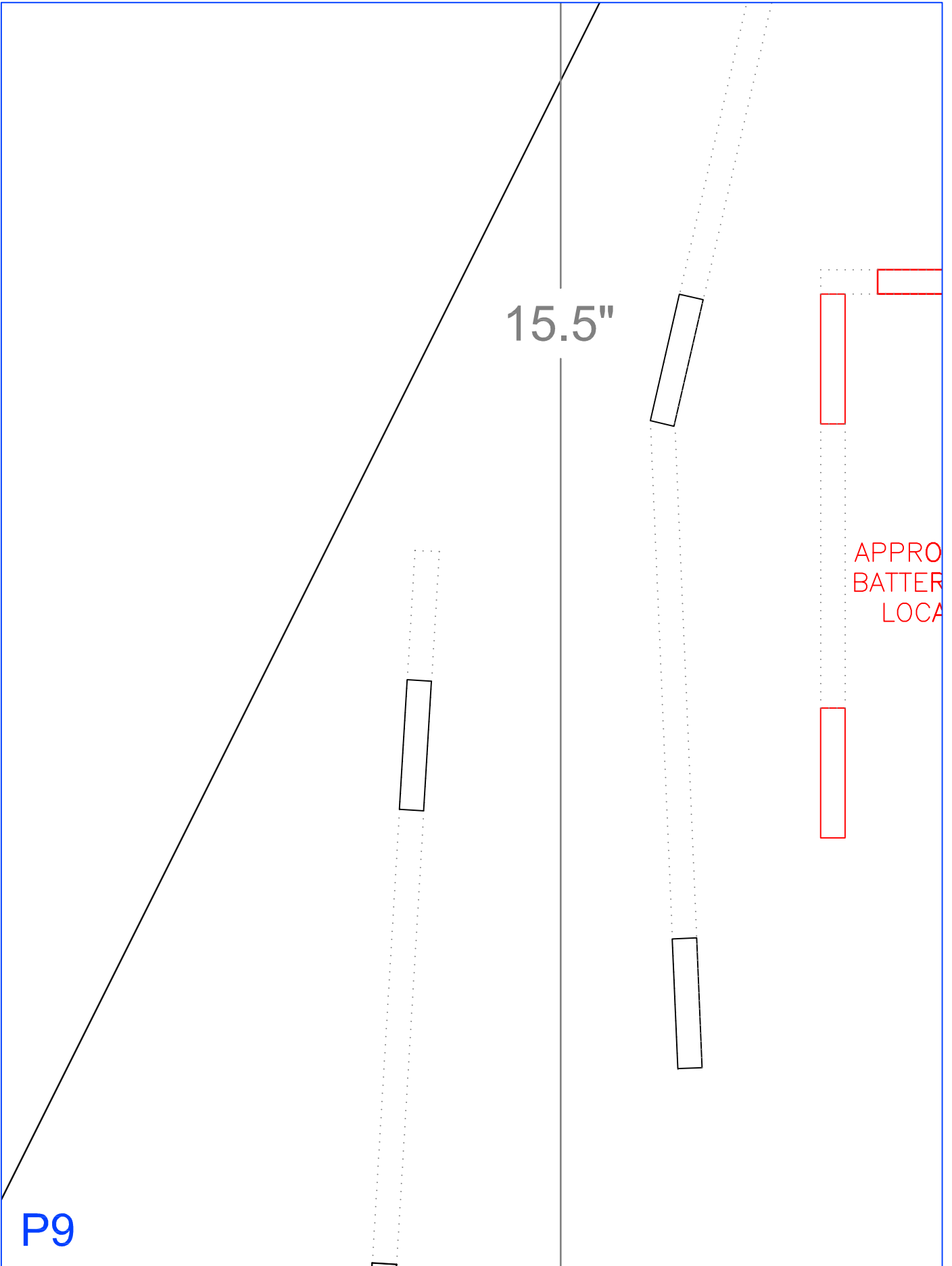

**VERIFY CG BEFORE YOU  
CUT NOTCHES AND  
MOUNT BATTERY BOX!  
LOCATION MAY NEED TO  
BE ADJUSTED FORWARD  
OR AFT DEPENDING ON  
EQUIPMENT TO BE USED!**

APPROXIMATE  
BATTERY BOX  
LOCATION

CUT ALL NOTCHES  
(DO NOT CUT  
THROUGH BOTTOM)

P10

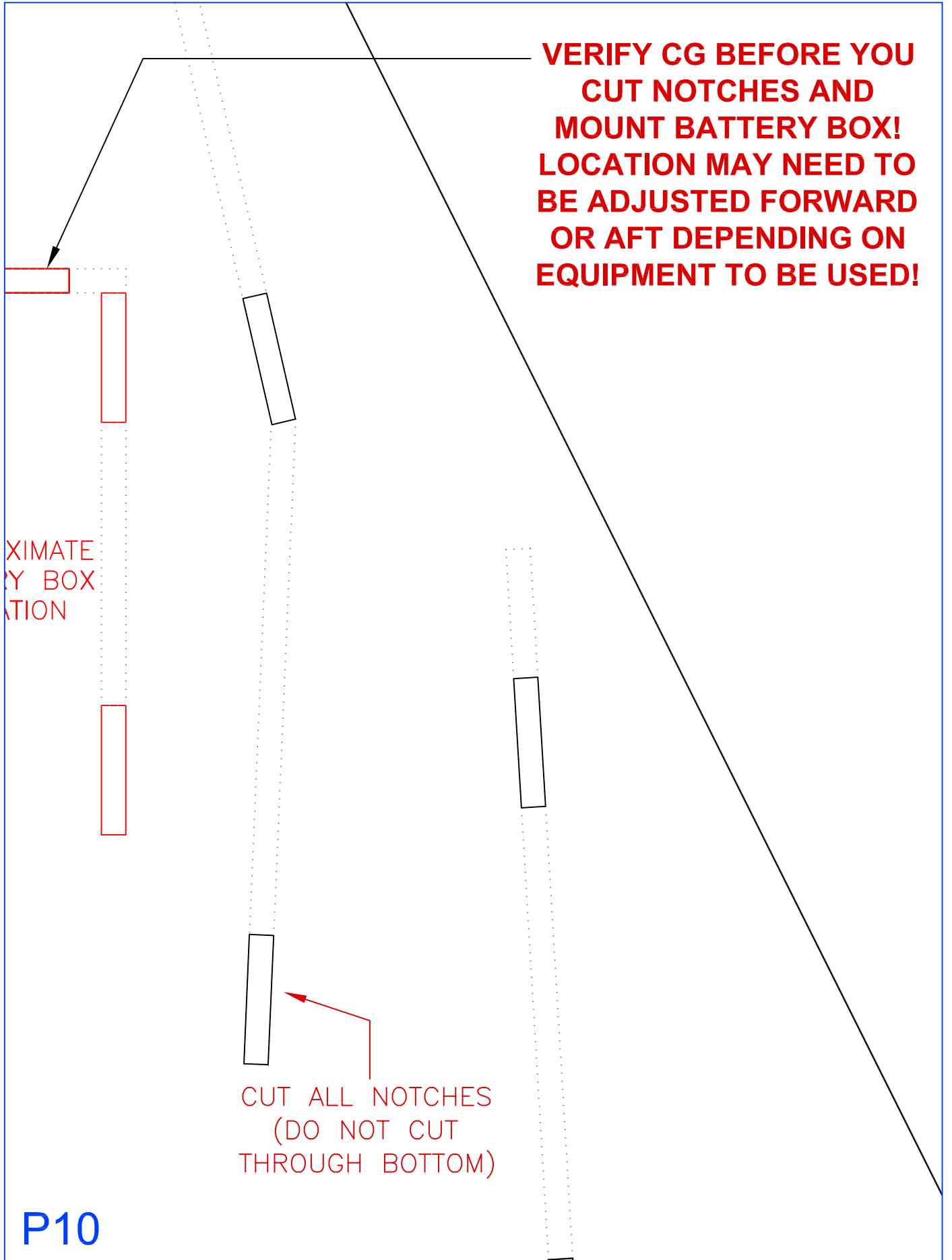

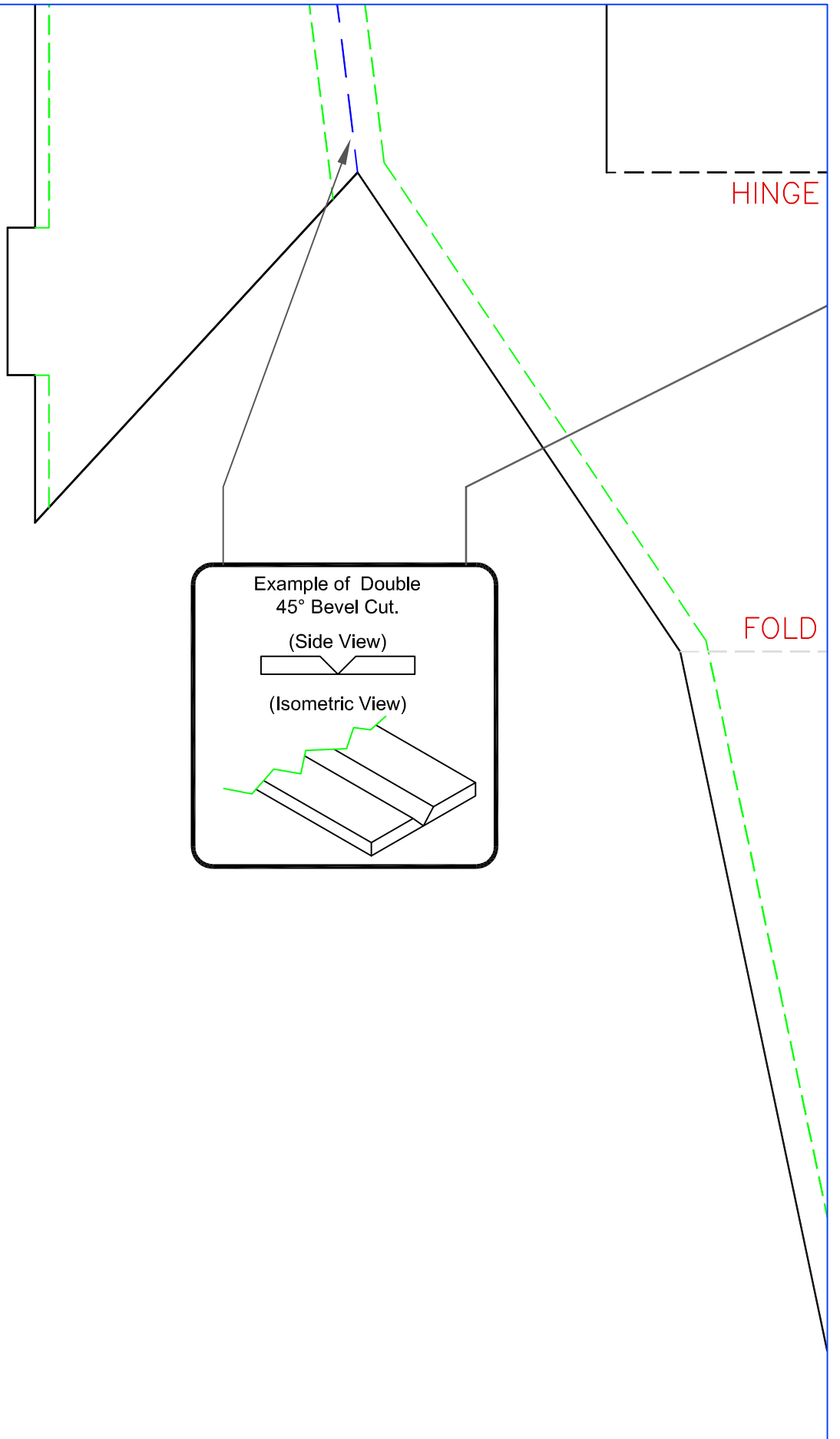

Example of Double  
45° Bevel Cut.

(Side View)



(Isometric View)

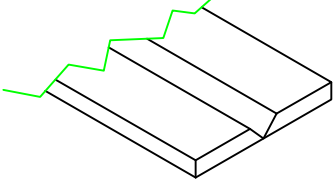

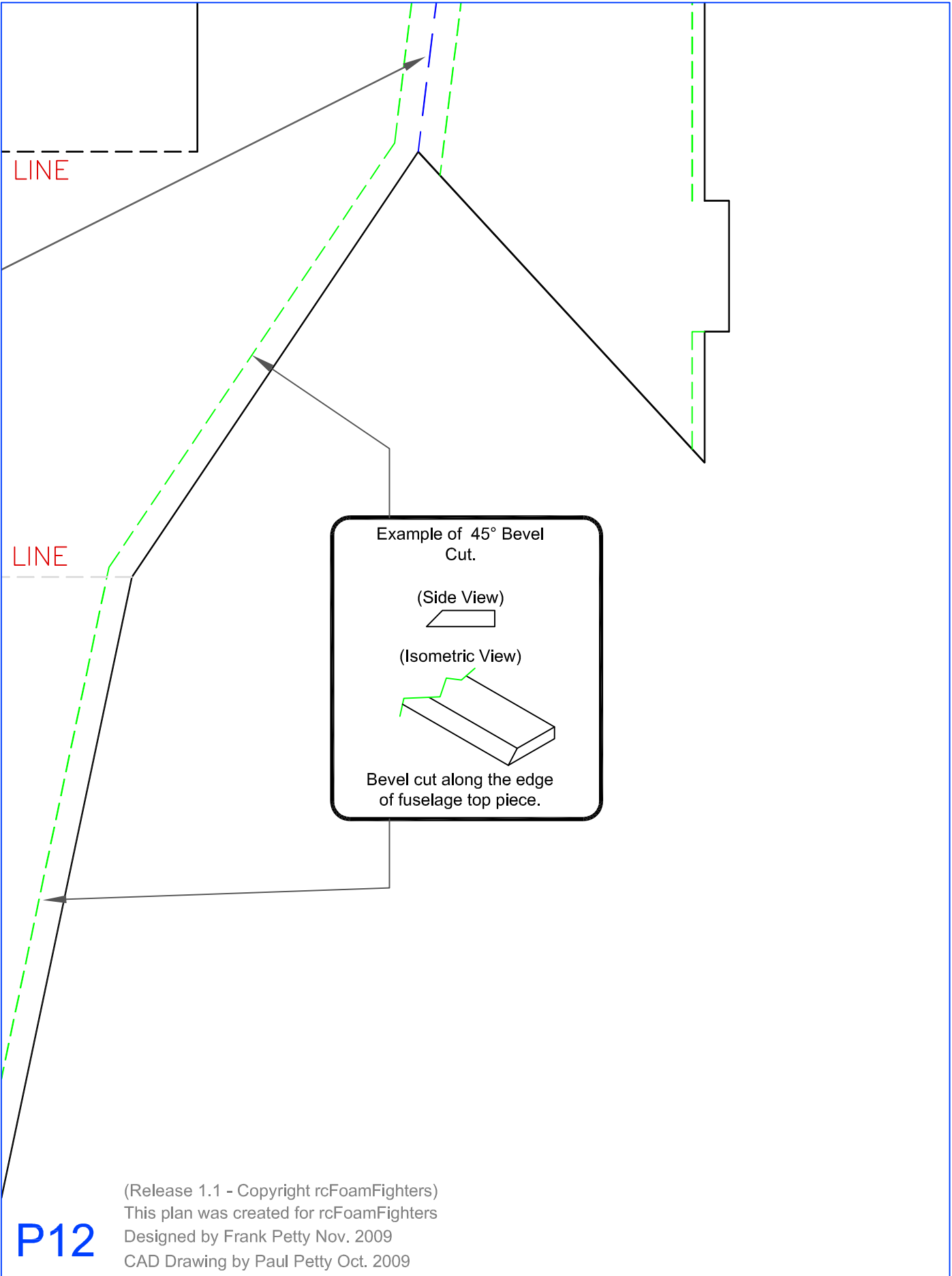

(Release 1.1 - Copyright rcFoamFighters)  
This plan was created for rcFoamFighters  
Designed by Frank Petty Nov. 2009  
CAD Drawing by Paul Petty Oct. 2009

P12

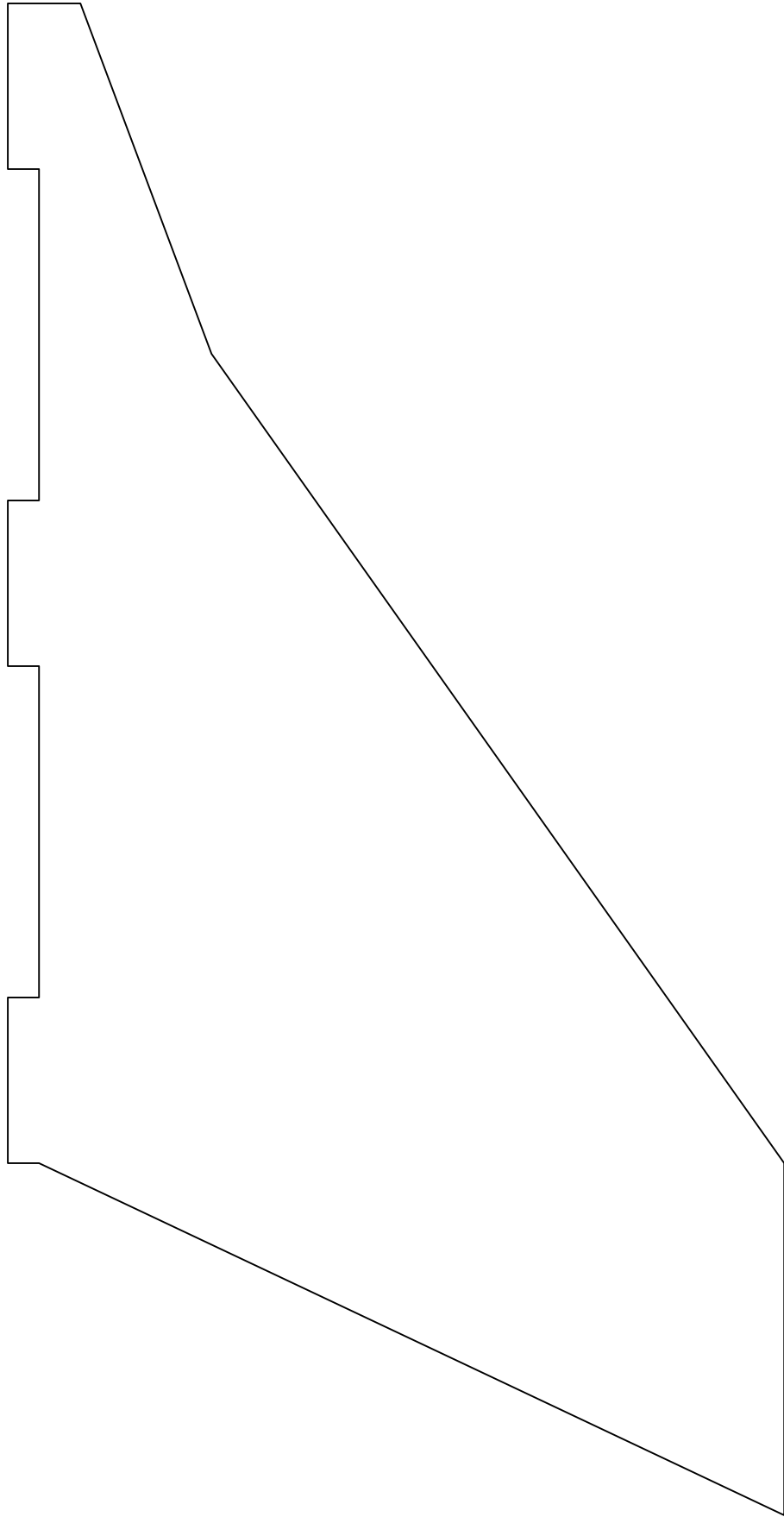

P13

P14

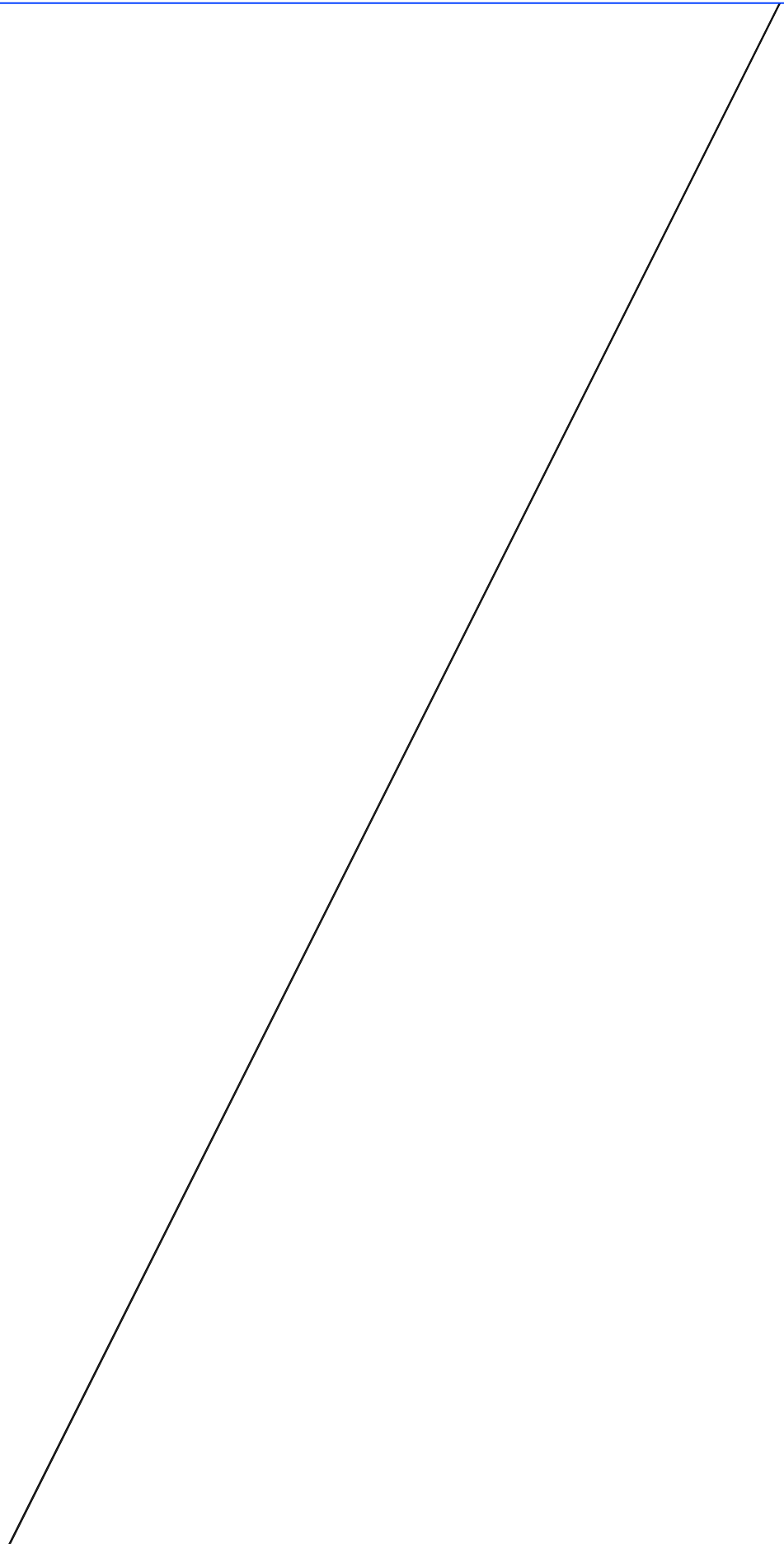

APPROXIMATE  
SERVO  
LOCATION

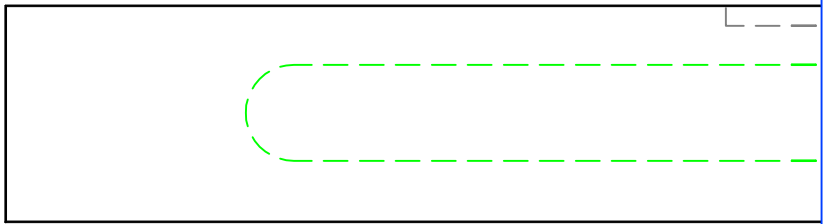
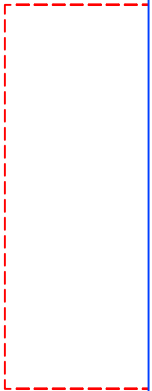
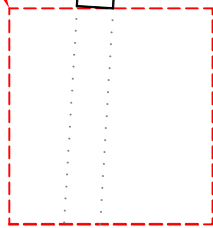
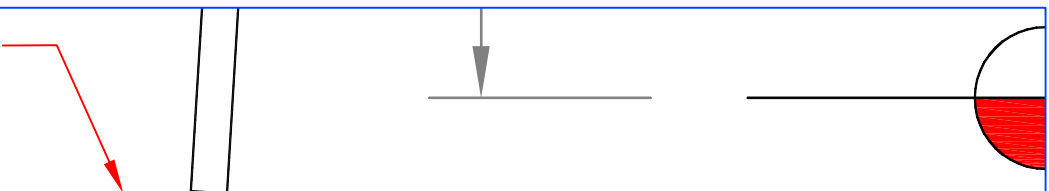

CUT AND REMOVE  
PROPELLER SLOT

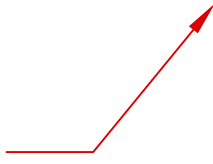

P15

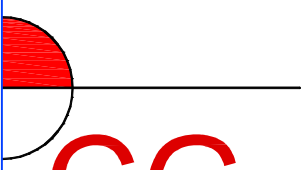

# CG

APPROXIMATE CG IS AT 15.5 INCHES BACK FROM THE TIP OF THE NOSE.

APPROXIMATE SERVO LOCATION

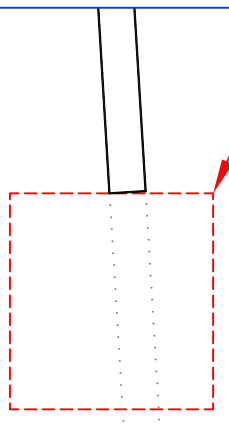

APPROXIMATE MOTOR MOUNT LOCATION. VERIFY WITH MOTOR TO BE USED.

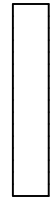
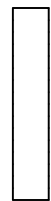
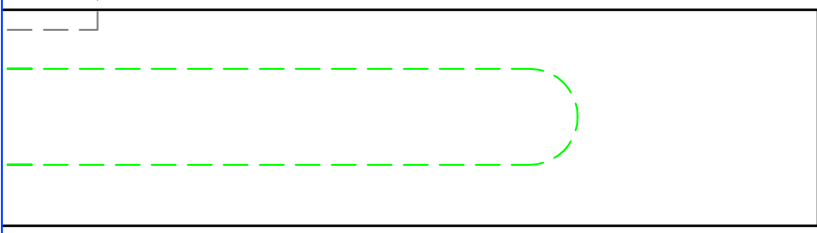
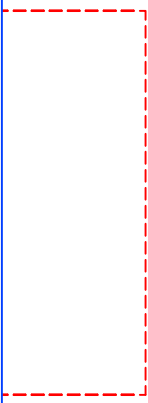



P17

### NOSE PIECES

CUT OUT ALL 4 NOSE  
PIECES AND GLUE  
TOGETHER WITH TWO  
TABED PIECES IN THE  
MIDDLE. NON TABBED  
PIECES TO BE GLUED  
ON THE OUTER SIDES.

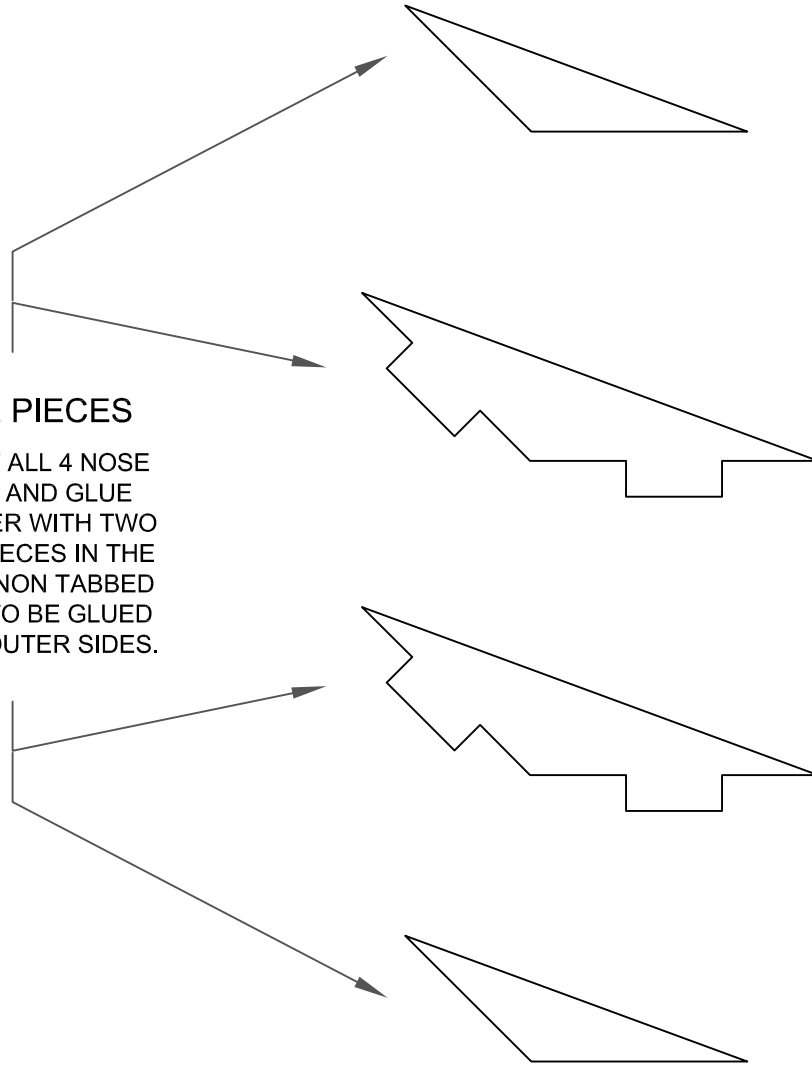

CUT AND  
HINGE LINE

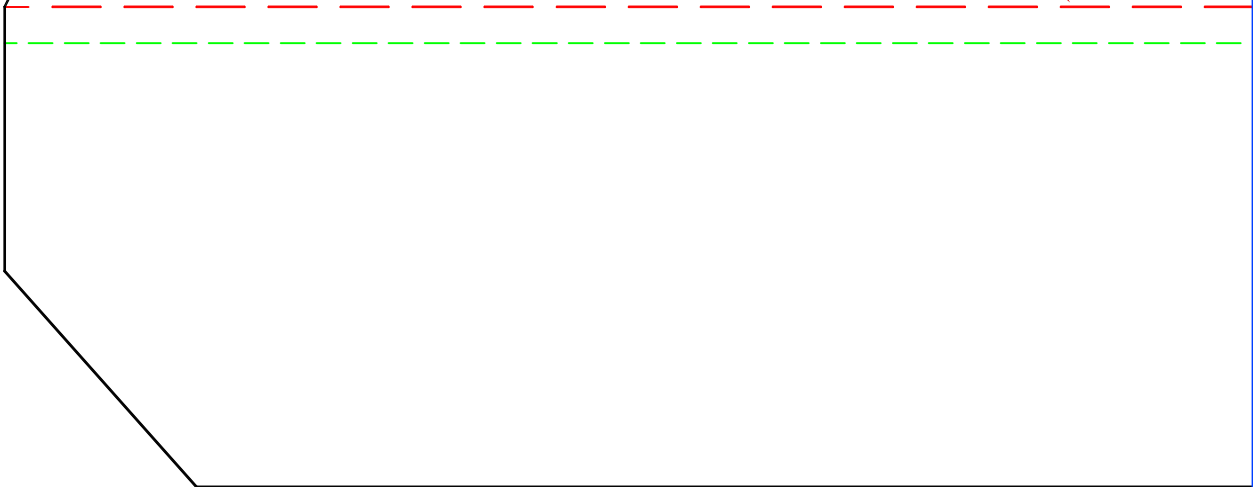

(Release 1.1 - Copyright rcFoamFighters)  
This plan was created for rcFoamFighters  
Designed by Frank Petty Nov. 2009  
CAD Drawing by Paul Petty Oct. 2009

P19

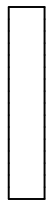

Example of 45° Bevel Cut.

(Side View)

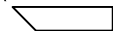

(Isometric View)

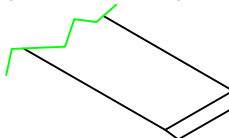

CUT ELEVONS ALONG THE CUT/HINGE LINE. AFTER THEY HAVE BEEN CUT OFF, CREATE A BEVEL CUT ALONG THE BOTTOM SIDE OF THE LEADING EDGE. THEN CREATE A TAPE HINGE TO SECURE ELEVON TO MAIN WING. (TYPICAL FOR BOTH ELEVONS)

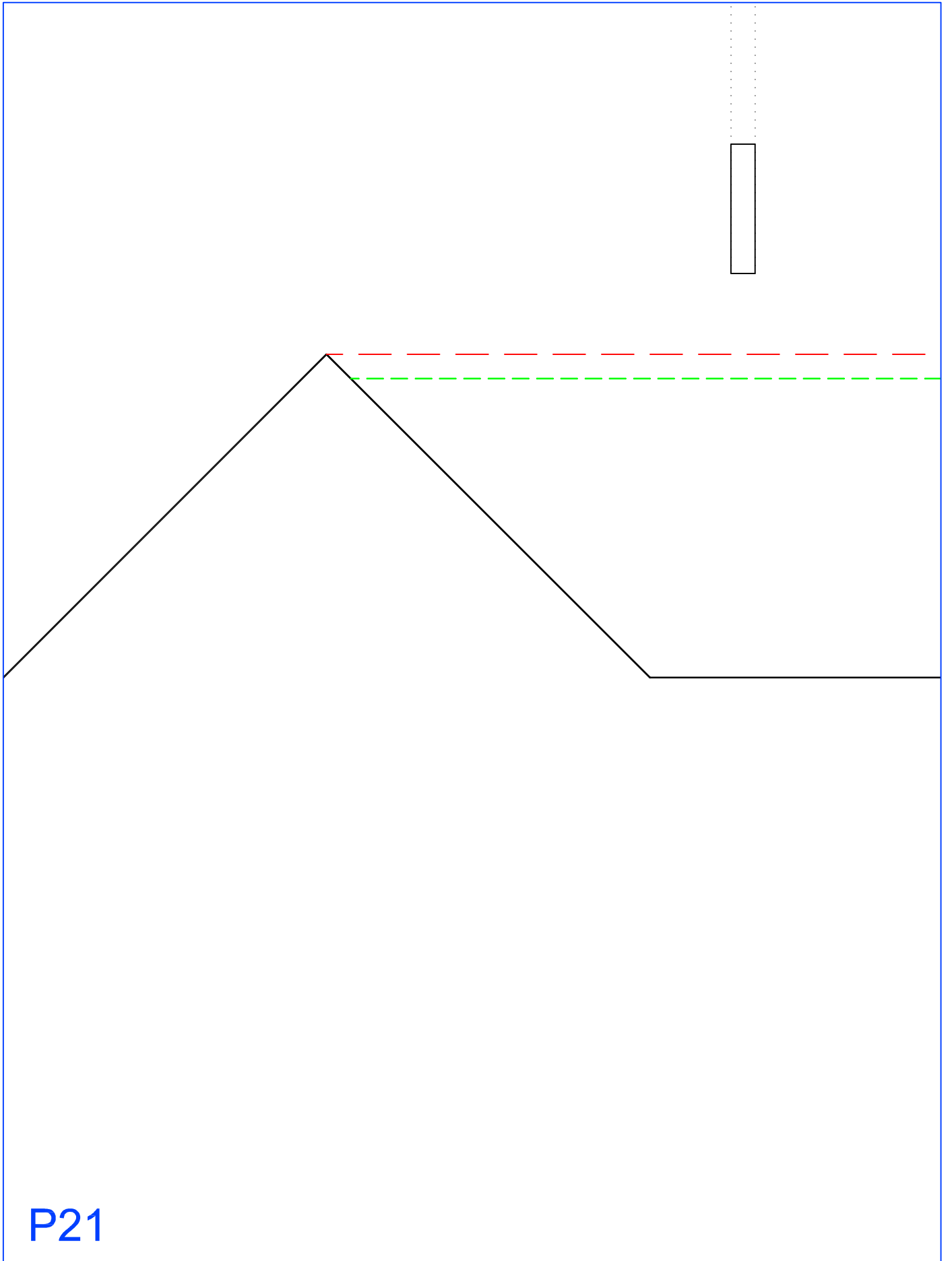

P21

CUT AND  
HINGE LINE

