



FOAM, GLUE, TAPE AND A LITTLE IMAGINATION....



(RC Model Airplane Construction Plans)

rcFoamFighters

MX-2 Frill Dragon

(Original Design by Jake Marshall - July. 2010)

(CAD Drawing by Jake Marshall - July 2010)

Basic Template Release Ver. 1.0

FREE PLAN - NOT TO BE SOLD

(Copyright, rcFoamFighters July 2010)

rcFoamFighters

MX-2 Frill Dragon Basic Template

(Design by Jake Marshall - July 2010)

(CAD Drawing by Jake Marshall - July 2010)

(Basic Template Release 1.0)

(Contact rcFoamFighters at: admin@rcfoamfighters.com)

(Please Visit Our Blog at: <http://rcfoamfighters.com/blog/>)

(Copyright, Jake Marshall of rcFoamFighters August 2010)

Basic Specs as built by rcFoamFighters:

Wingspan: 26 Inches (66.04cm)

Length: 26.88 Inches (68.28cm)

All Up Weight (AUW): 22oz. (623.7gms)

Est. Top Speed: 85mph (136.77kph)

Note, weight and top speed may vary depending on materials, motor, battery and electronics used. The weight given here is based on the model rcFoamFighters made using Foamboard.

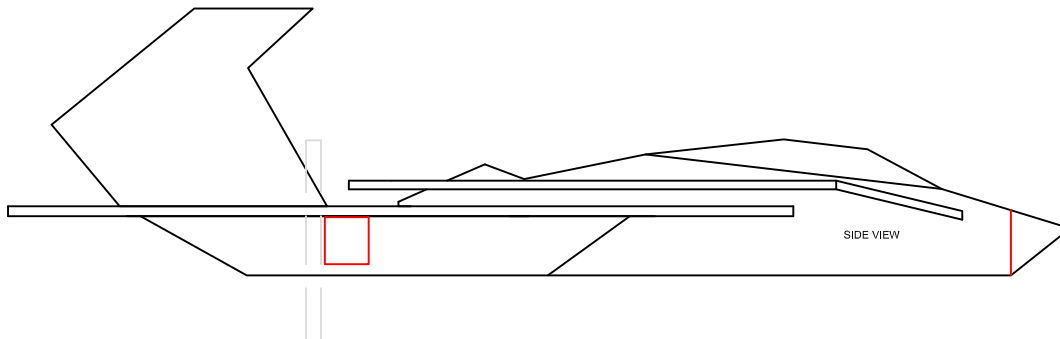

Description:

This RC model was designed to represent the fierce Frill Dragon Lizard, to accomplish the look of this reptile, optional air-brakes in the shape of its Frill neck skin was represented. The plane was originally setup with Elevrons only, however the plane can be modified to accommodate Ailerons and a single Elevator in the back for extreme performance. The original RC model design was made with Foamboard and covered with colored sealing/packing tape. Other materials such as Depron and Fan Fold Foam may be used to make this model.

Copy Disclaimer

rcFoamFighters grants permission for this plan to be copied at local copy houses for personal use only. This plan may not be Sold, or Altered to remove the rcFoamFighters contact information or instructions.

(Contact rcFoamFighters at: admin@rcfoamfighters.com)

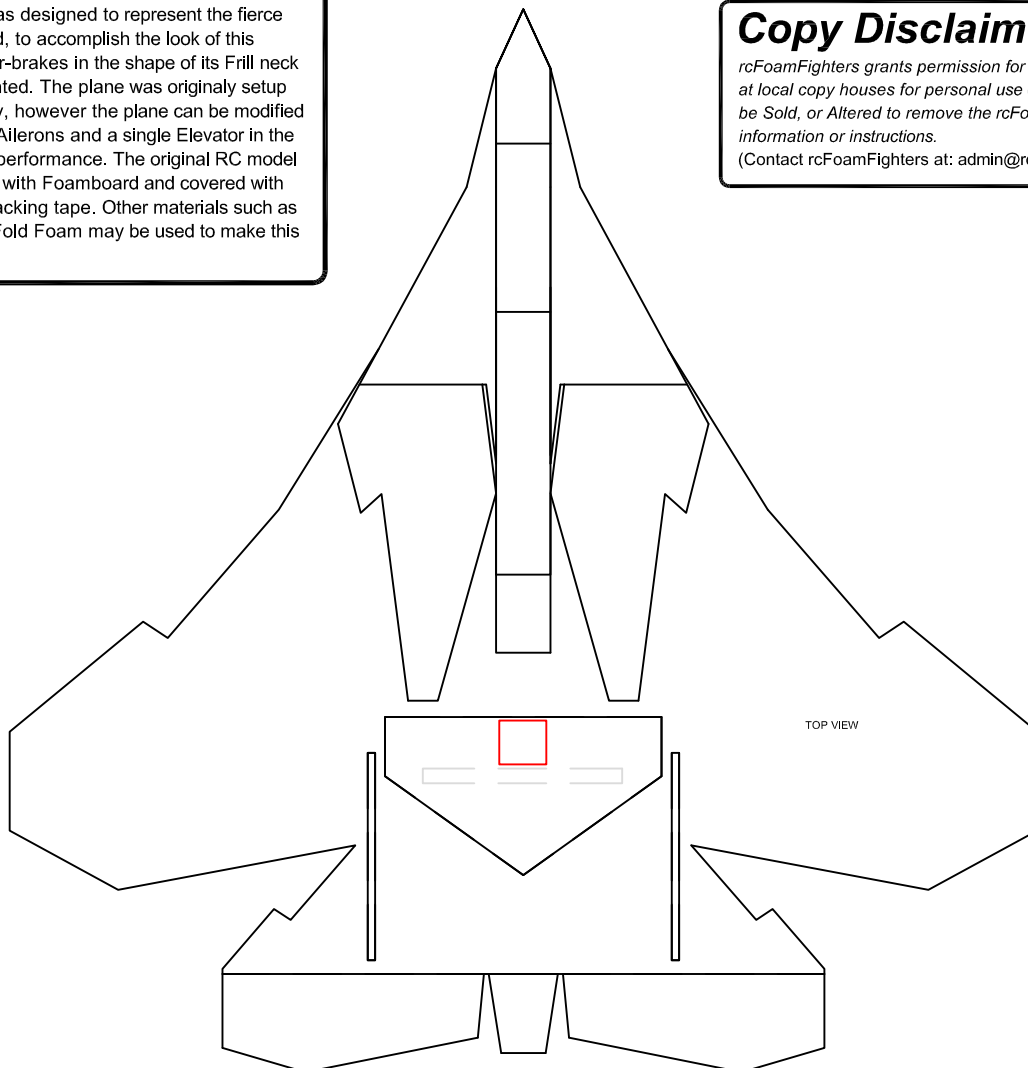

Recommend Parts:

BASIC SETUP (65+mph)

Motor: Suppo A2212/6 2200kV Brushless Motor
ESC: Suppo 30A Brushless ESC
Prop: APC 6x4
Battery: 2200mA (25C or better recommended)
Servos: 4 Metal Gear with Air-Brakes (2 without)
Radio & Receiver: Any 6-channel or better (2.4ghz preferred)

PERFORMANCE SETUP (85+mph)

Motor: Grayson Hobbies "Super Mega Jet" 2550kV Motor
ESC: 50A Brushless ESC
Prop: APC 6x5.5
Battery: 2200mA (30C recommended)
Servos: 4 Metal Gear with Air-Brakes (2 without)
Radio & Receiver: Any 6-channel or better (2.4ghz preferred)

Plane was originally designed to be made from 20x30 Sheets of Foamboard.
Depron or FanFold Foam with Carbon Spars may be used .

Disclaimer (Please Read):

- This is a design template for a high performance, high speed RC aircraft. This plane should only be built and flown by experienced pilots with adequate skill to fly fast, maneuverable planes.
- **DO NOT fly this plane where it can endanger people, livestock or property.**
- **ANY PERSONS DECIDING TO BUILD AND FLY THIS PLANE DOES SO AT HIS/HER OWN RISK AND LIABILITY. RCFOAMFIGHTERS ASSUMES NO RESPONSIBILITY FOR THE PERFORMANCE OF THIS PLANE.**
- This plane should only be launched via the side launch method. Do not attempt to launch from the top or bottom of the fuselage. Doing so can cause **EXTREME BODILY HARM** if any hand or body part comes into contact with the fast spinning propeller.
- All minors should fly under the supervision of an adult or guardian.

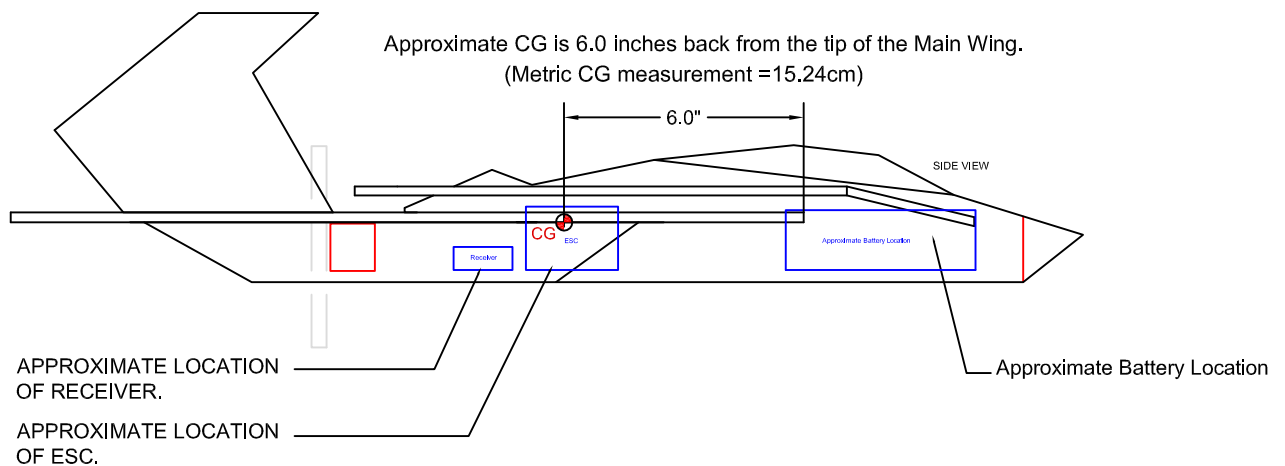

SCRATCH BUILT BASSWOOD MOTOR MOUNT (MADE FROM 3/32" BASSWOOD SHEETS)

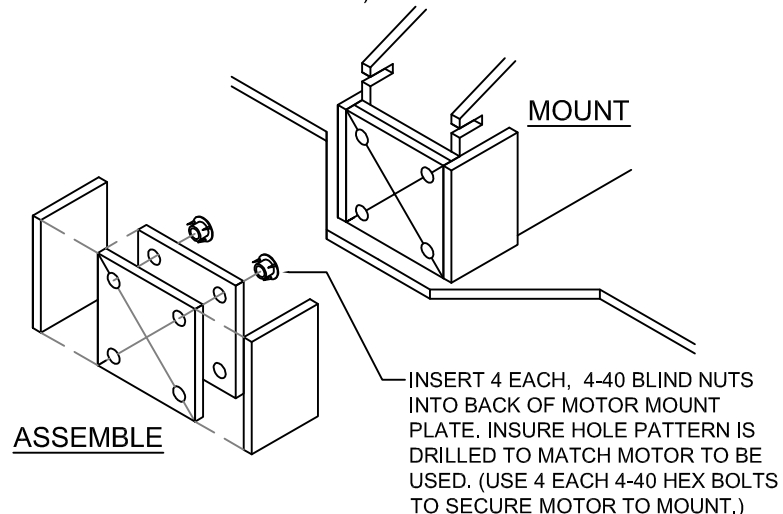

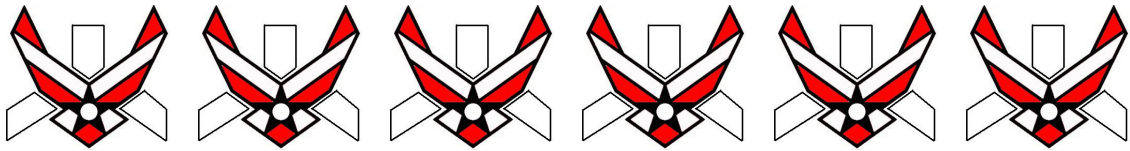
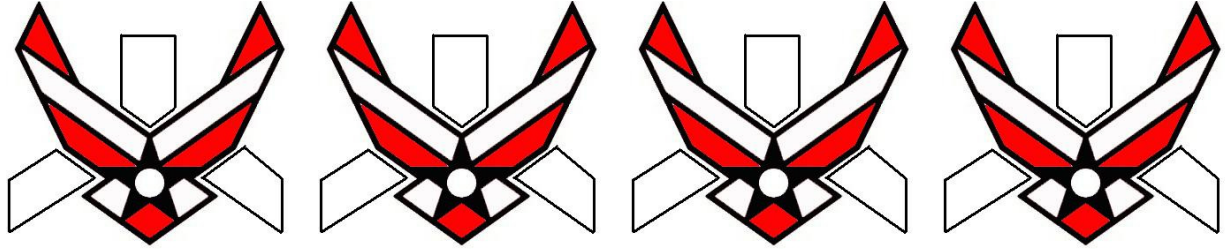
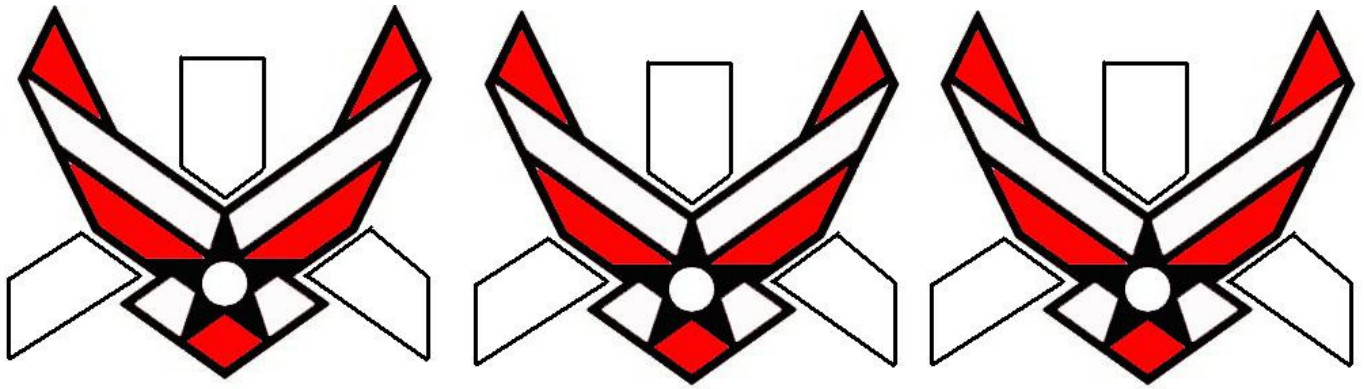

MX-2

MX-2



FRILL DRAGON

FRILL DRAGON

P1

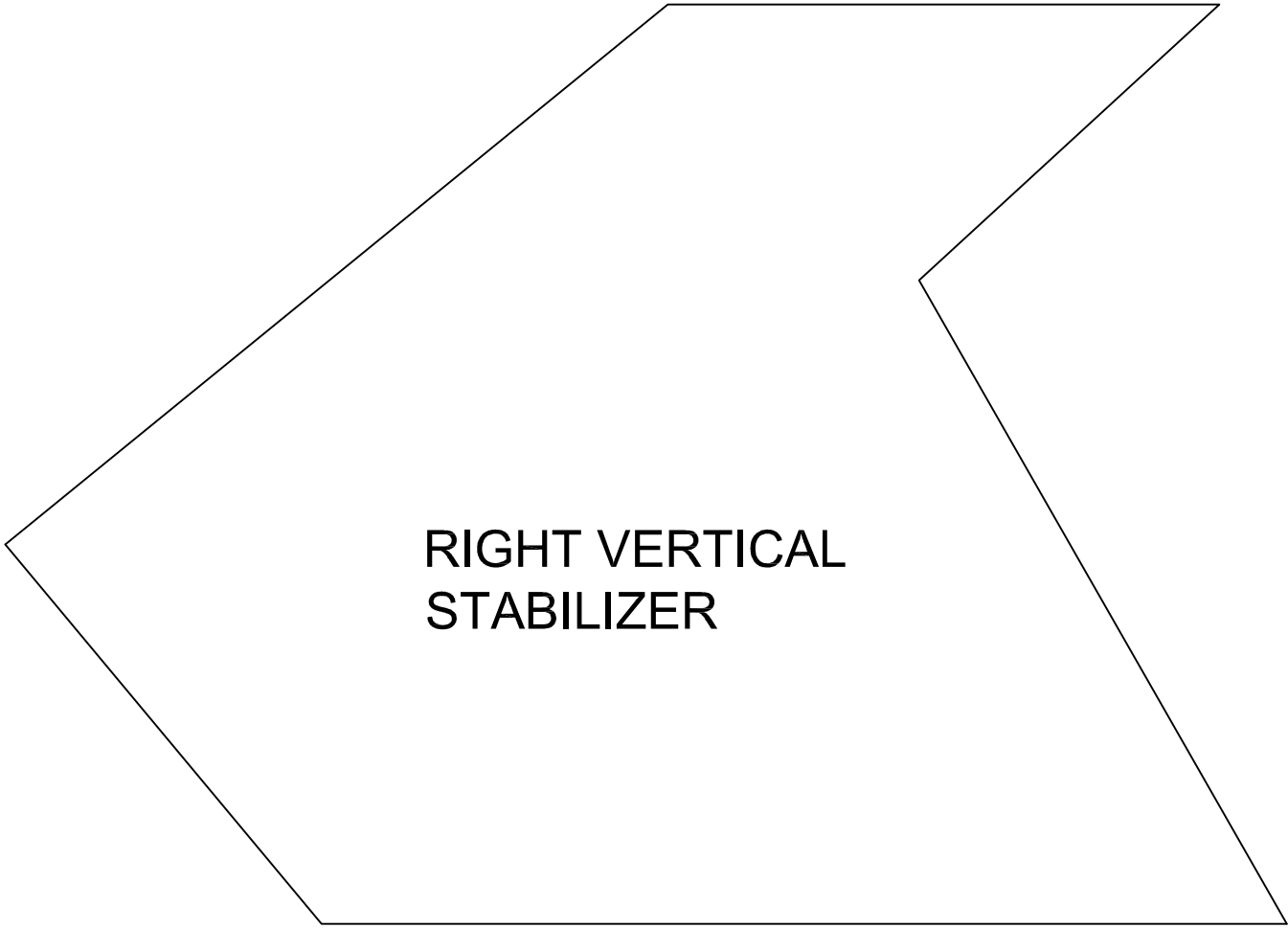

**RIGHT VERTICAL
STABILIZER**

P3

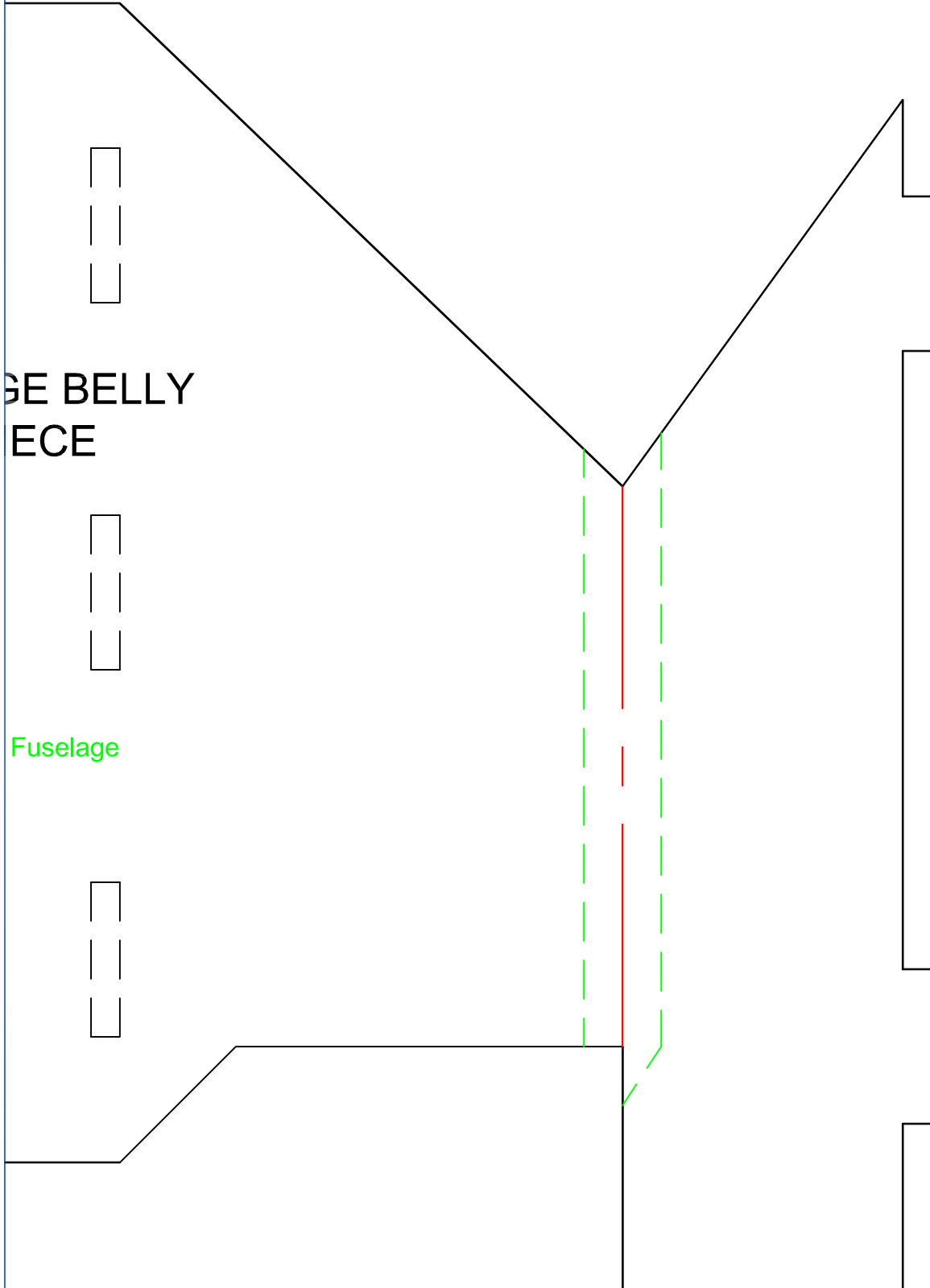

P4

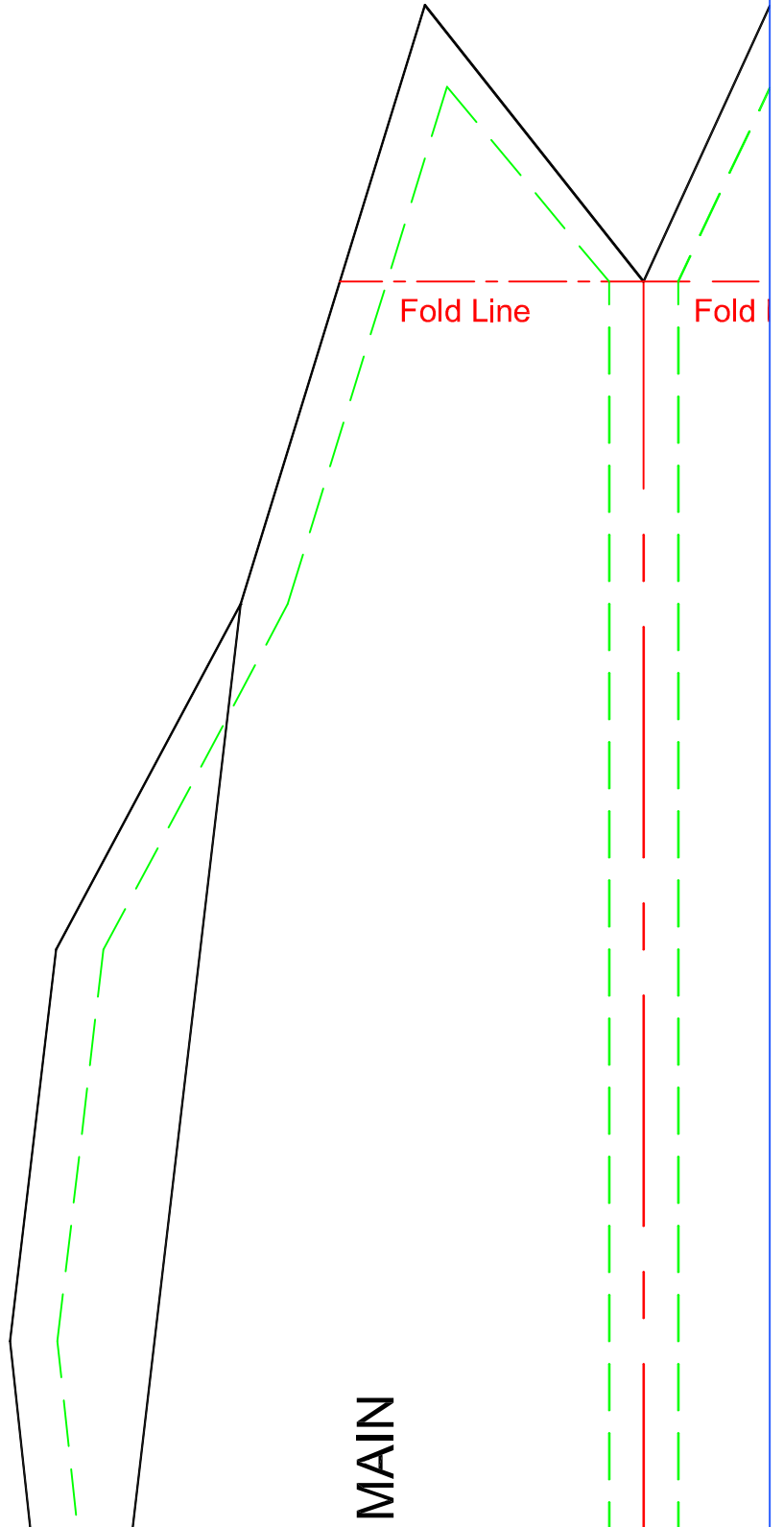

P5

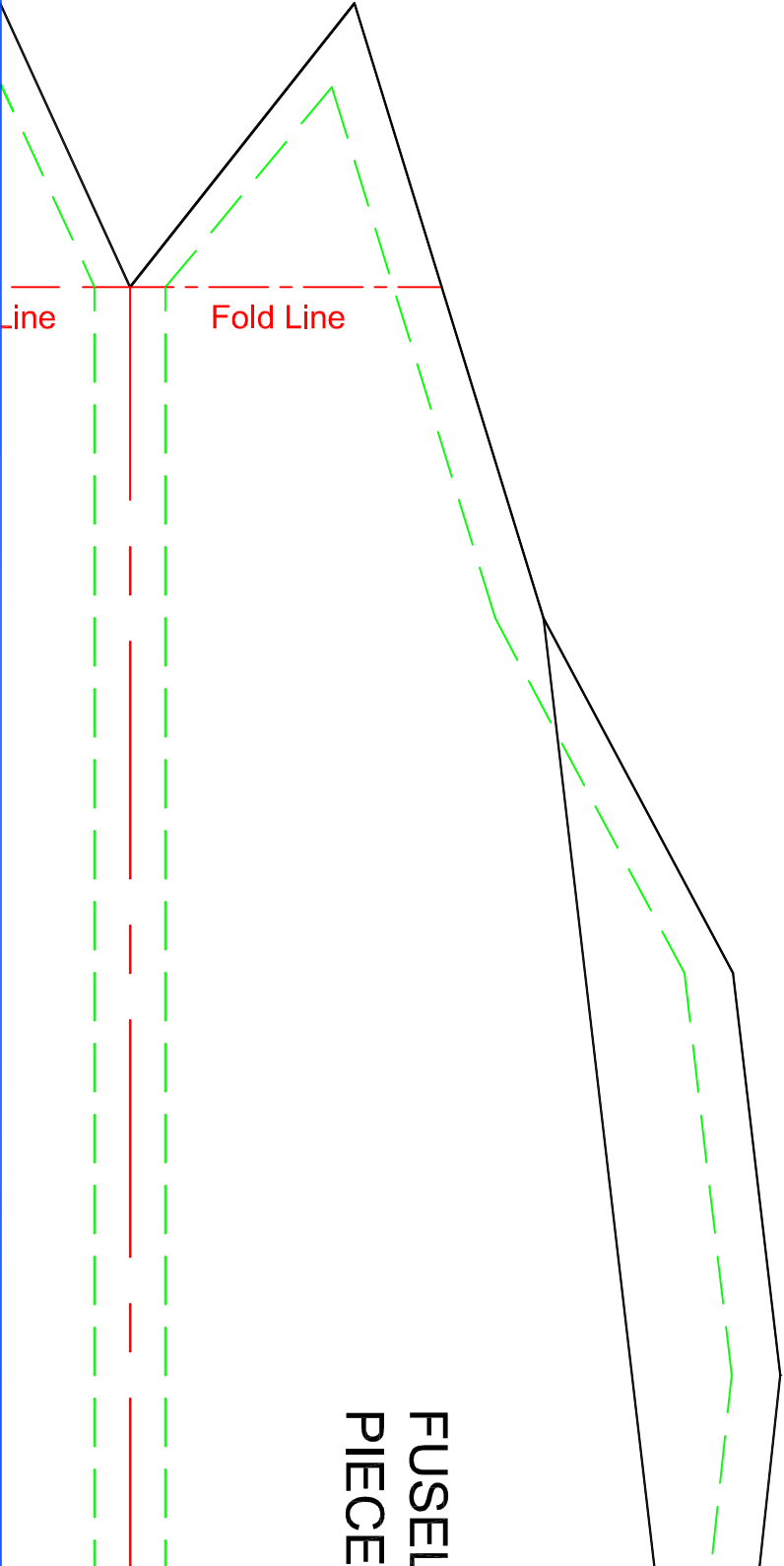

FUSEL
PIECE

P6

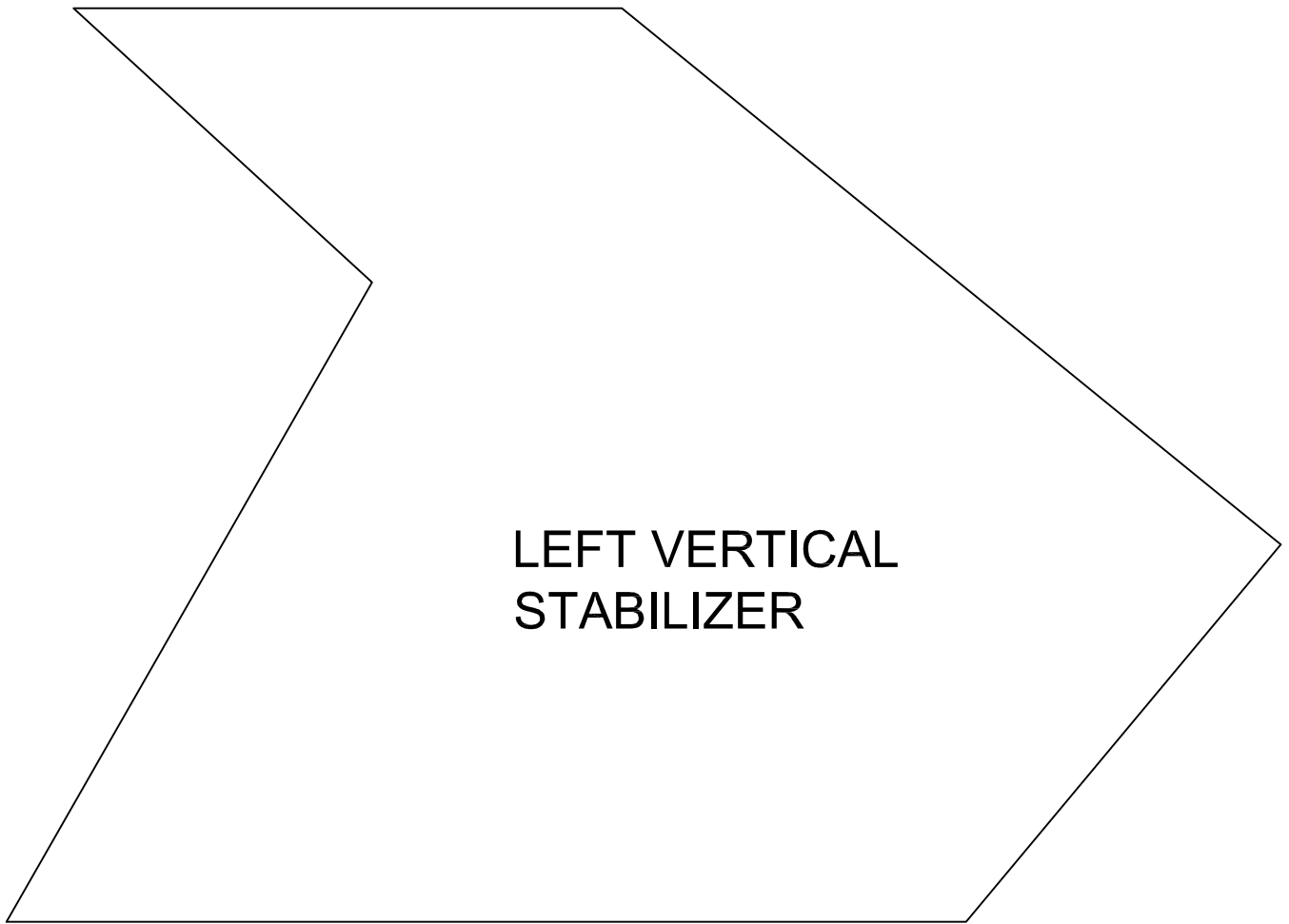

LEFT VERTICAL
STABILIZER

P2

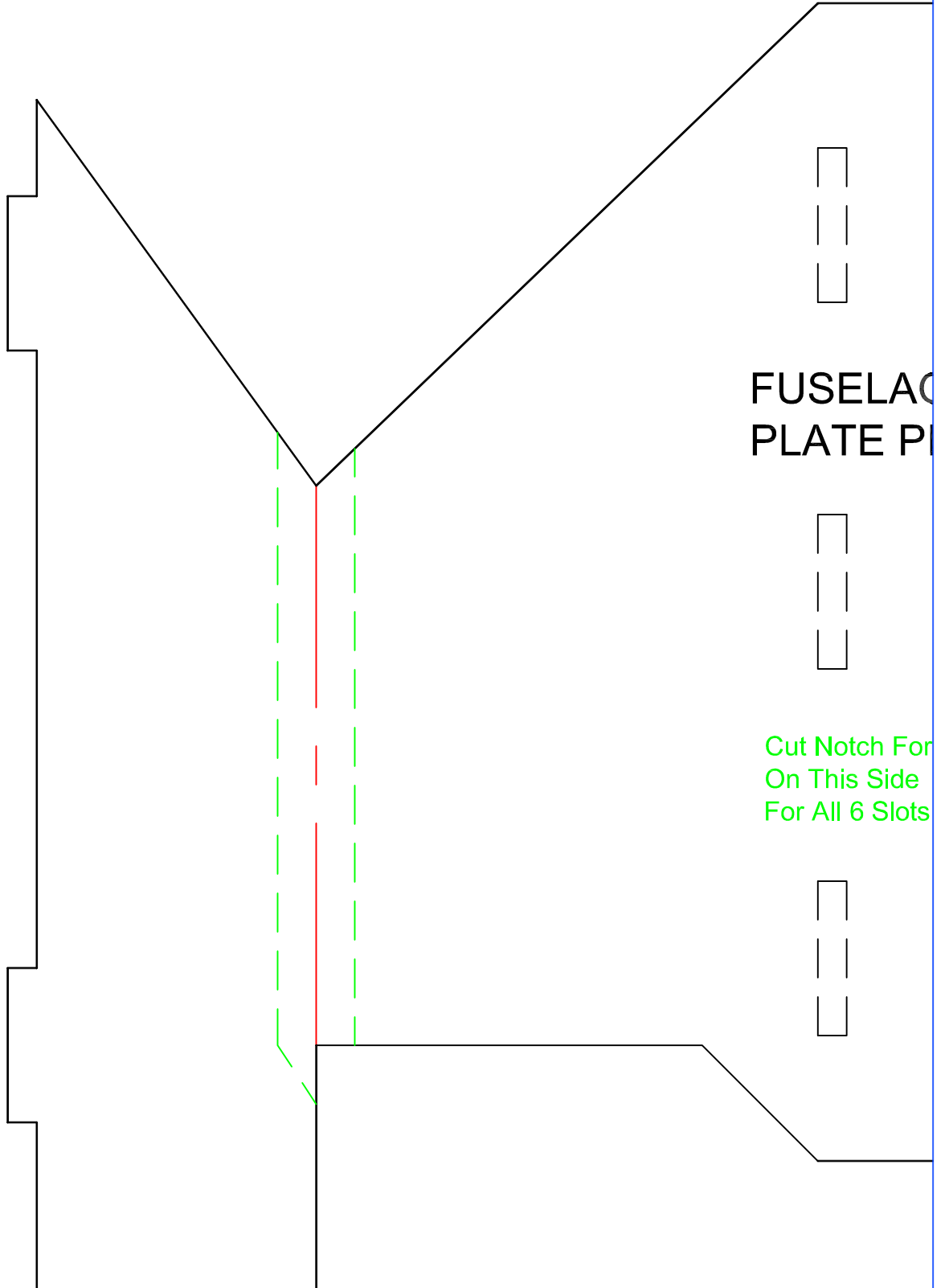

FUSELAGE
PLATE P2

Cut Notch For
On This Side
For All 6 Slots

P7

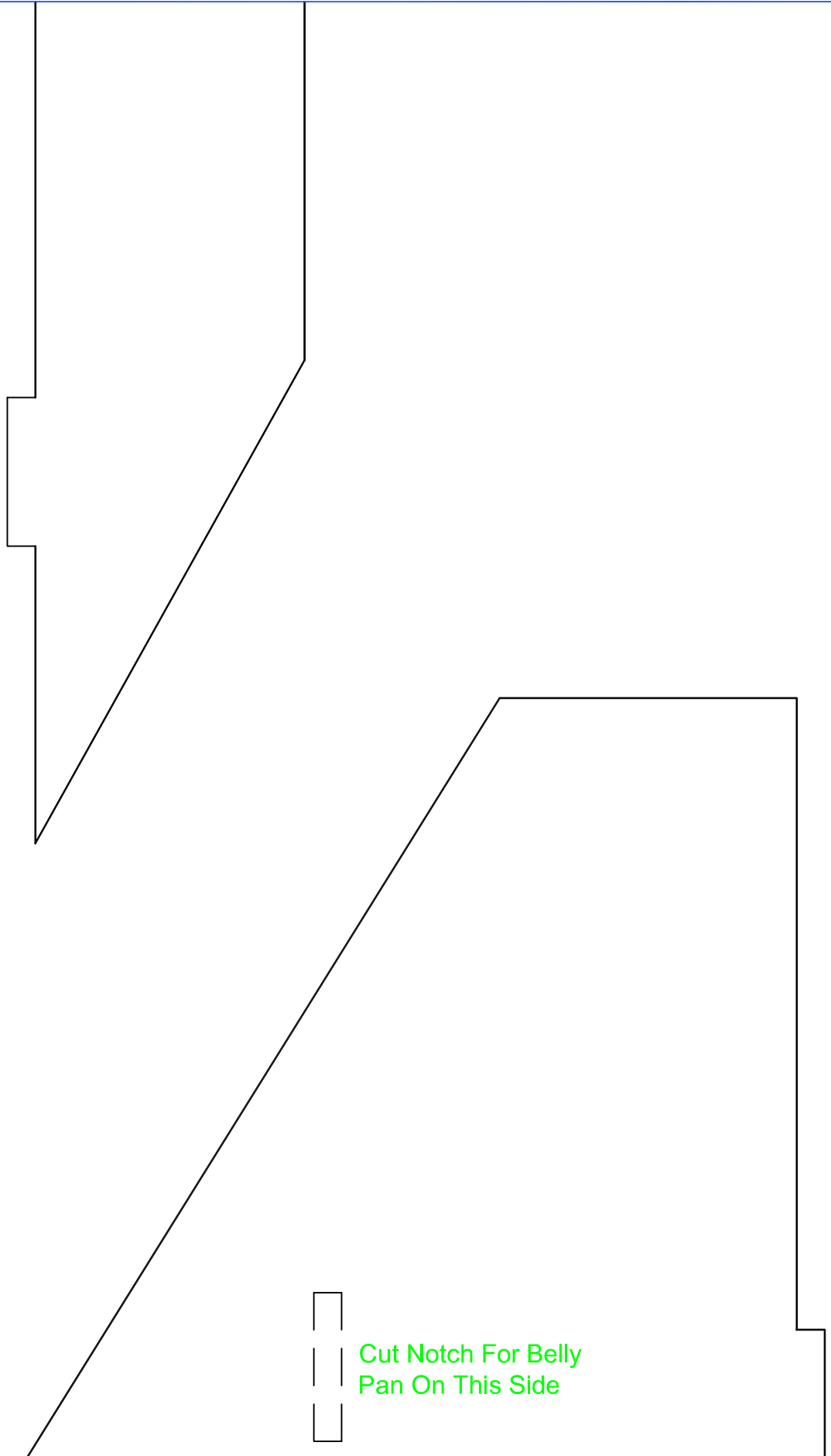

Cut Notch For Belly
Pan On This Side

P8

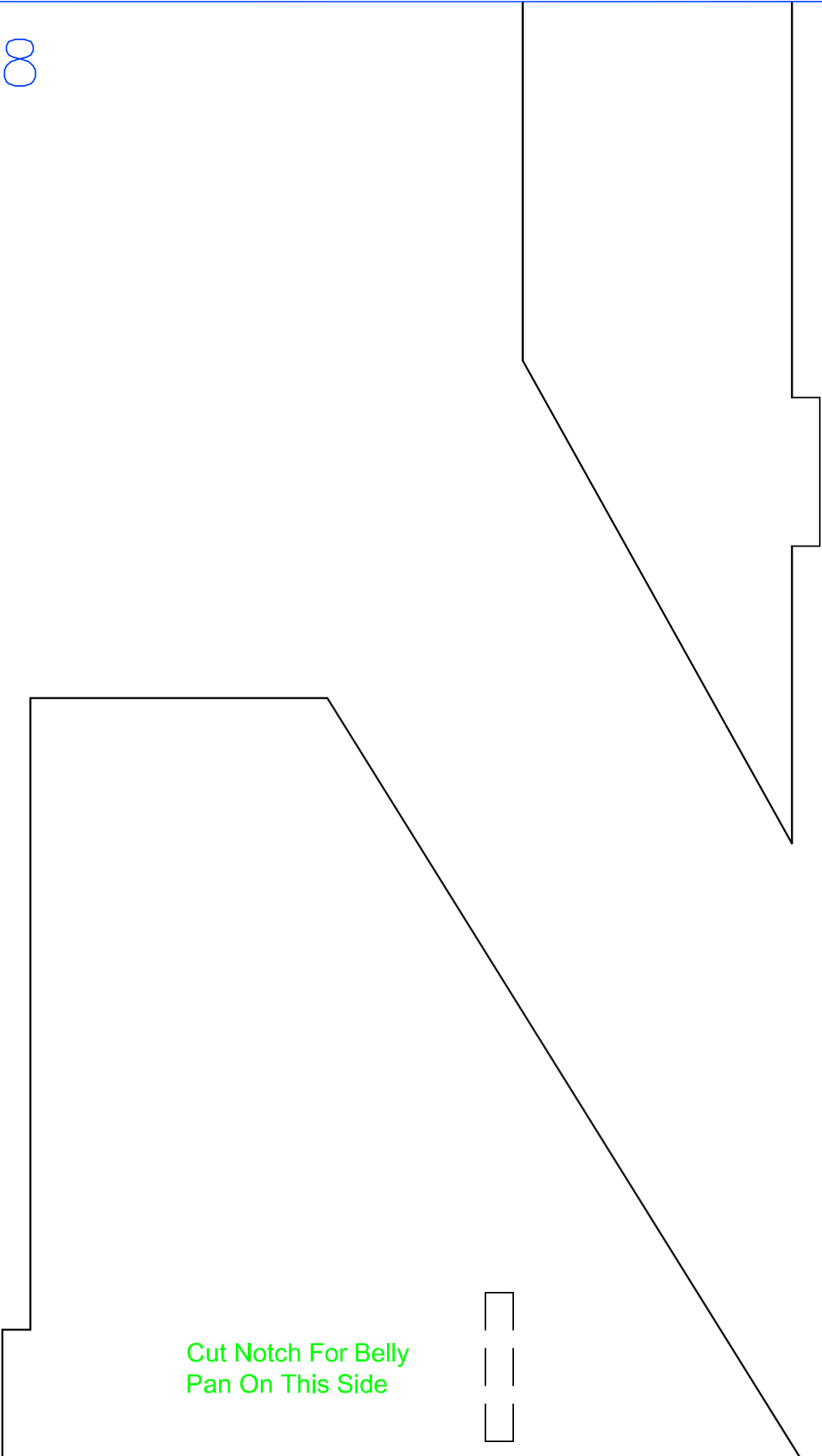

Cut Notch For Belly
Pan On This Side



FUSELAGE
PIECE

Cut Notch Through

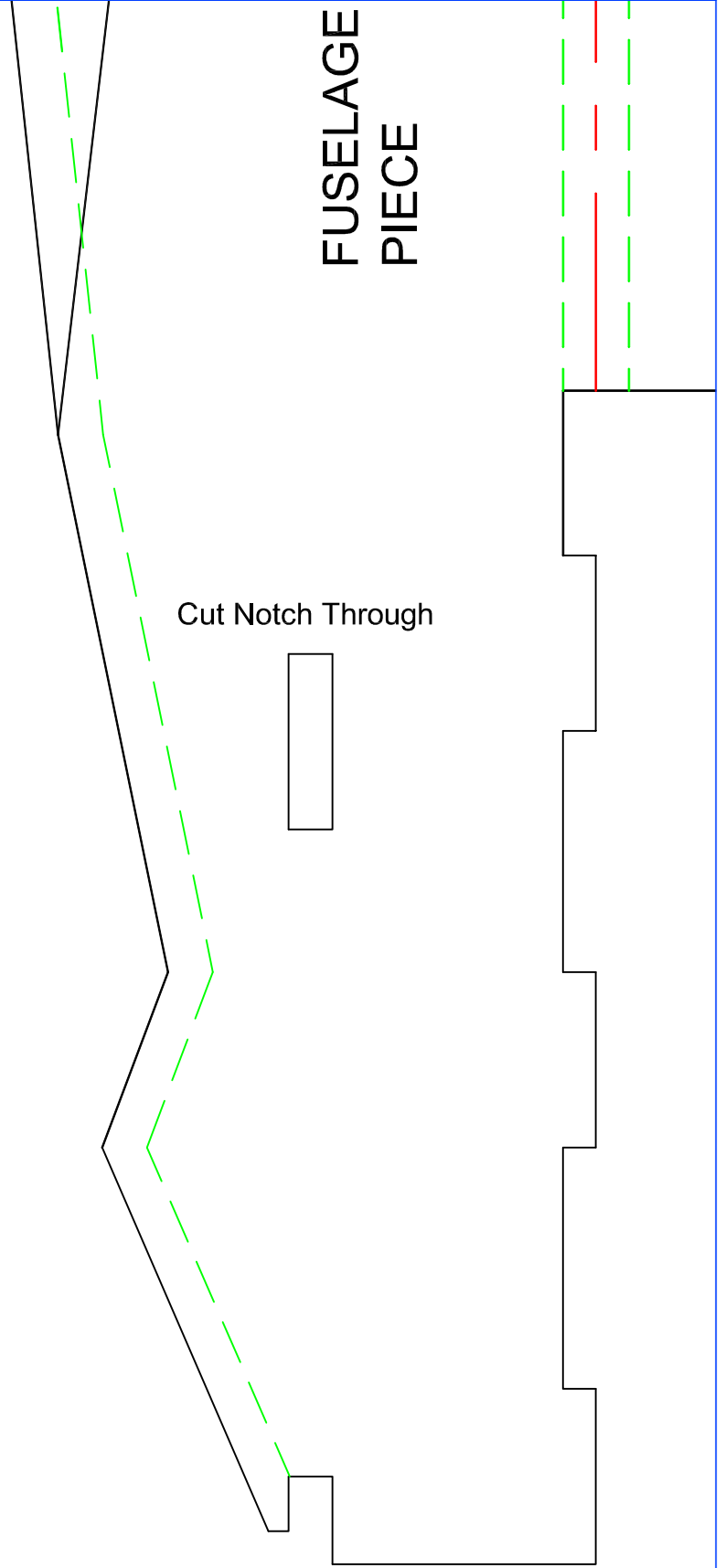
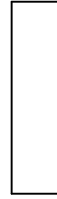

P10

AGE MAIN

Cut Notch Through

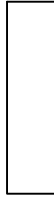

Fold Line

Rough Servo
Location

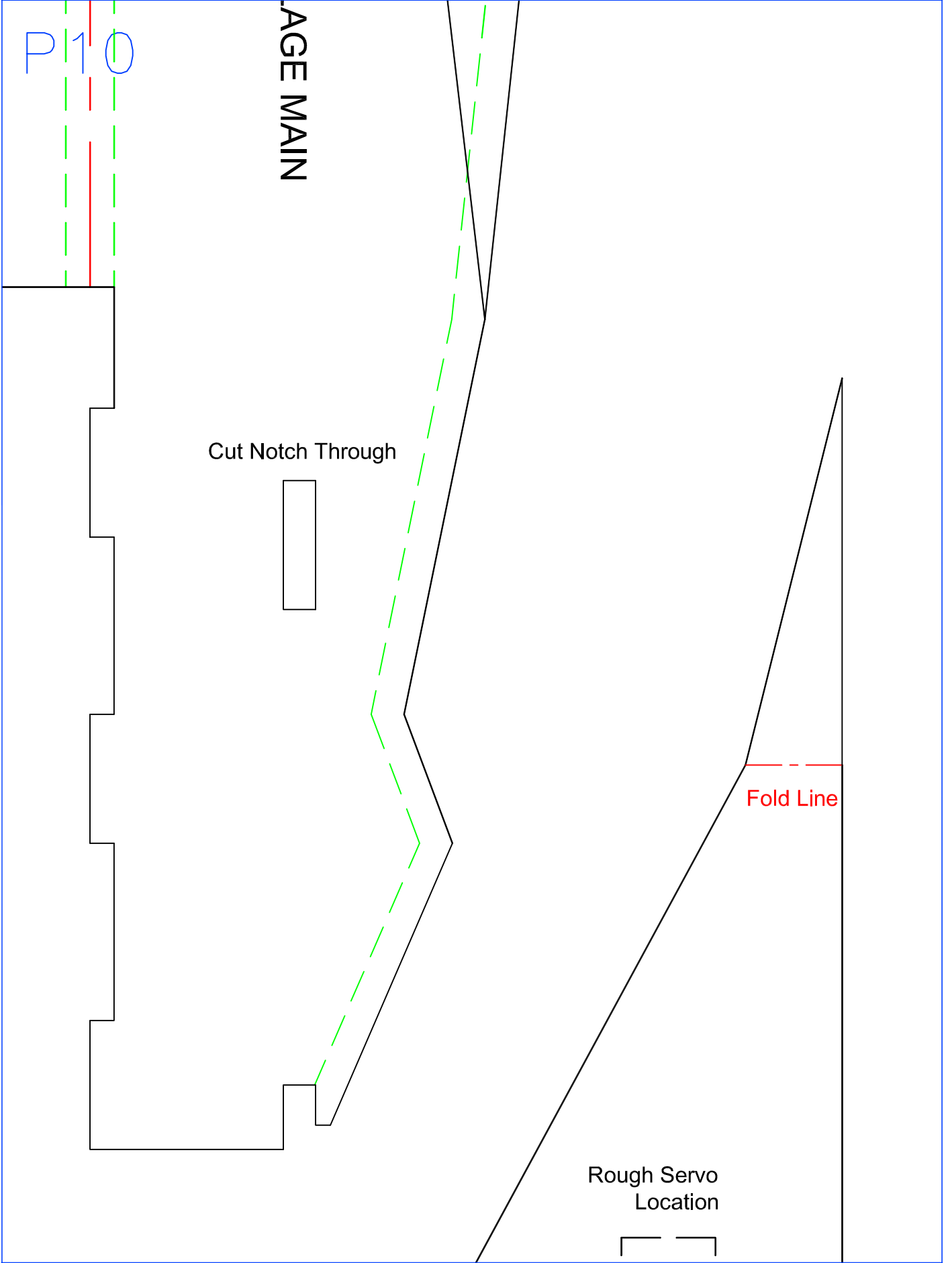
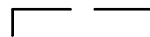

P 11

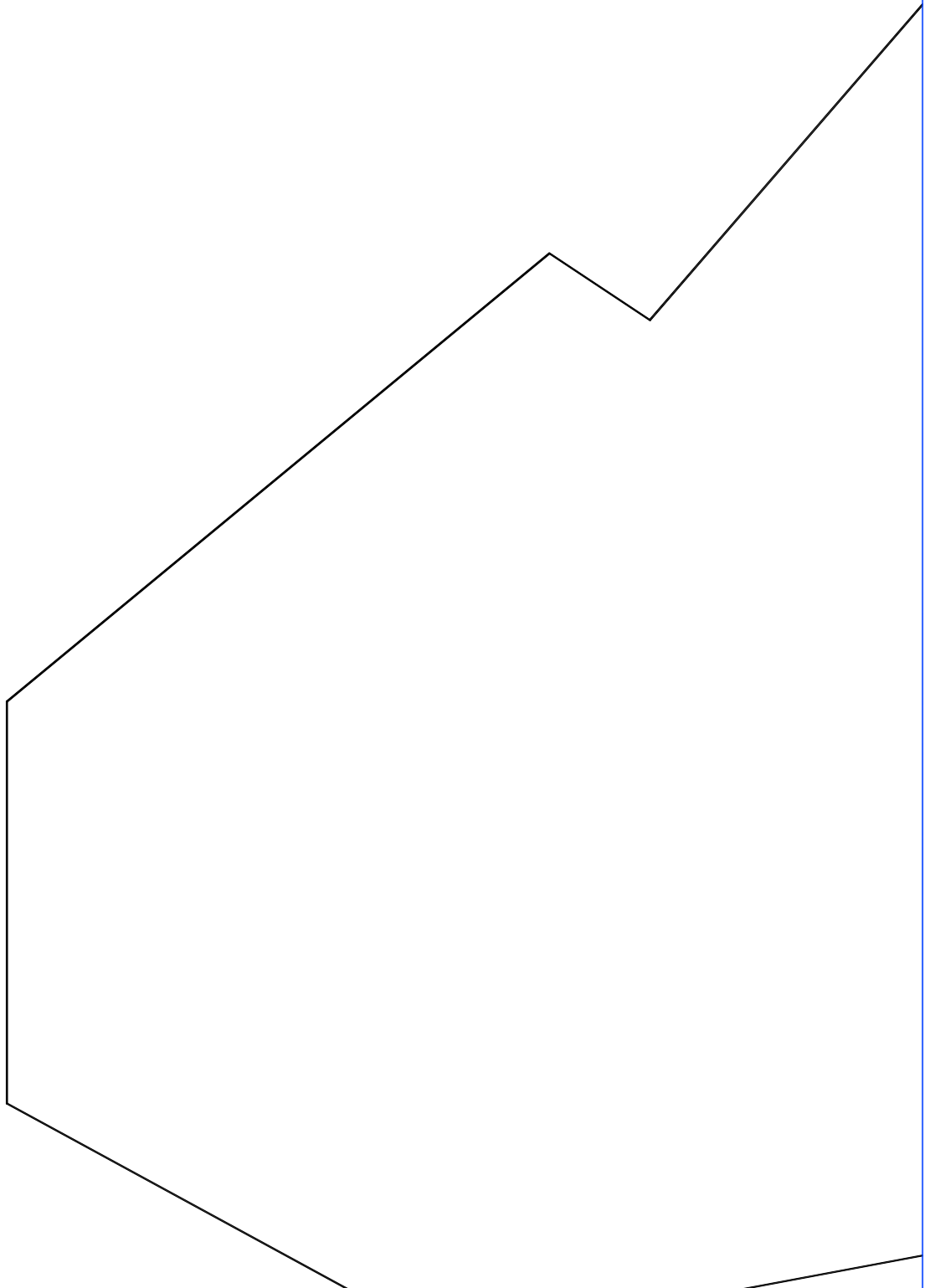

P12

Center of Gravity 6 Inches From Top
of Main Wing Piece



Cut Notch For Belly
Pan On This Side

MAIN WING



Cut Notch For Belly
Pan On This Side

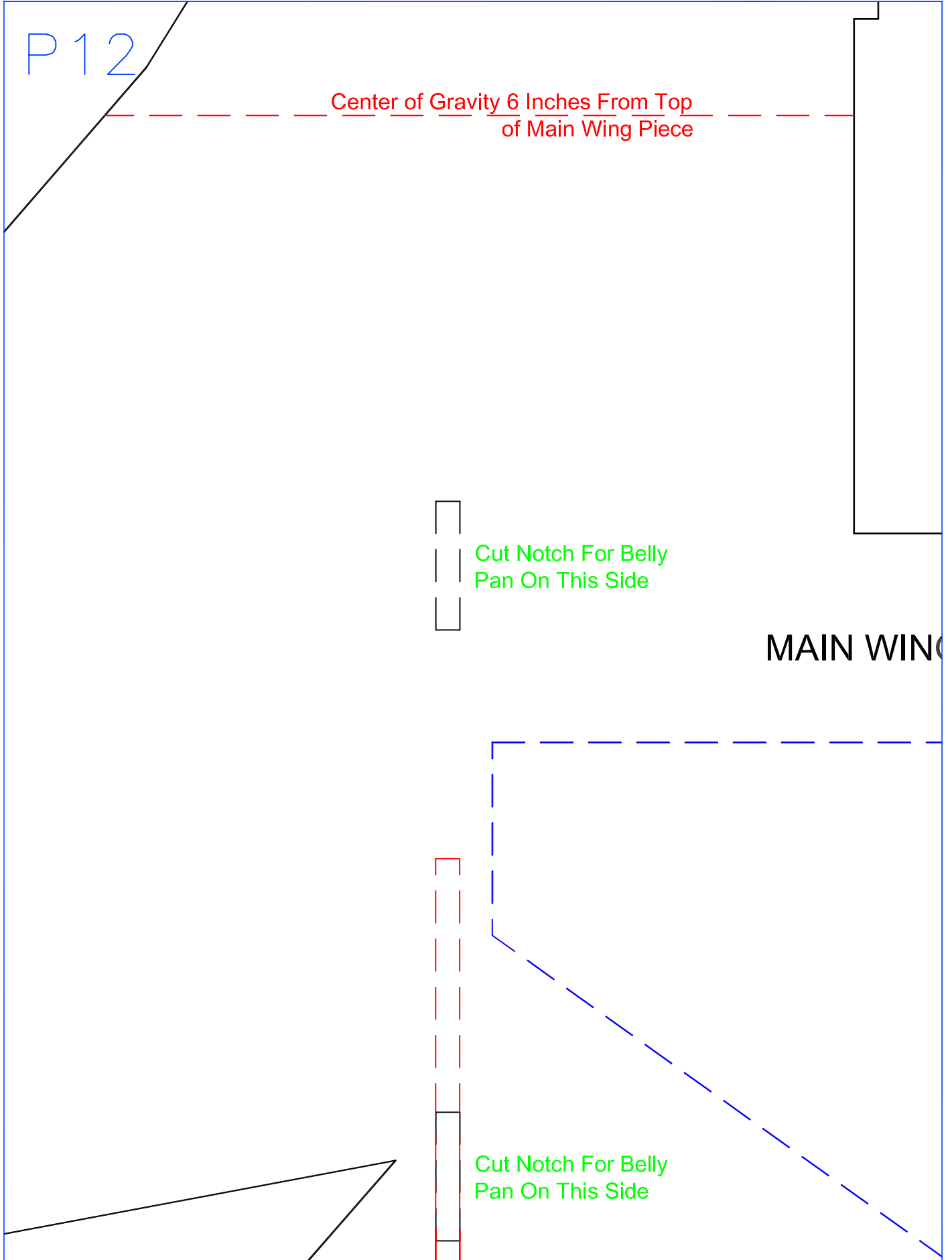

P 13

Center of Gravity 6 Inches From Top
of Main Wing Piece

Cut Notch For Belly
Pan On This Side

G PIECE

Cut Notch For Belly
Pan On This Side



P14

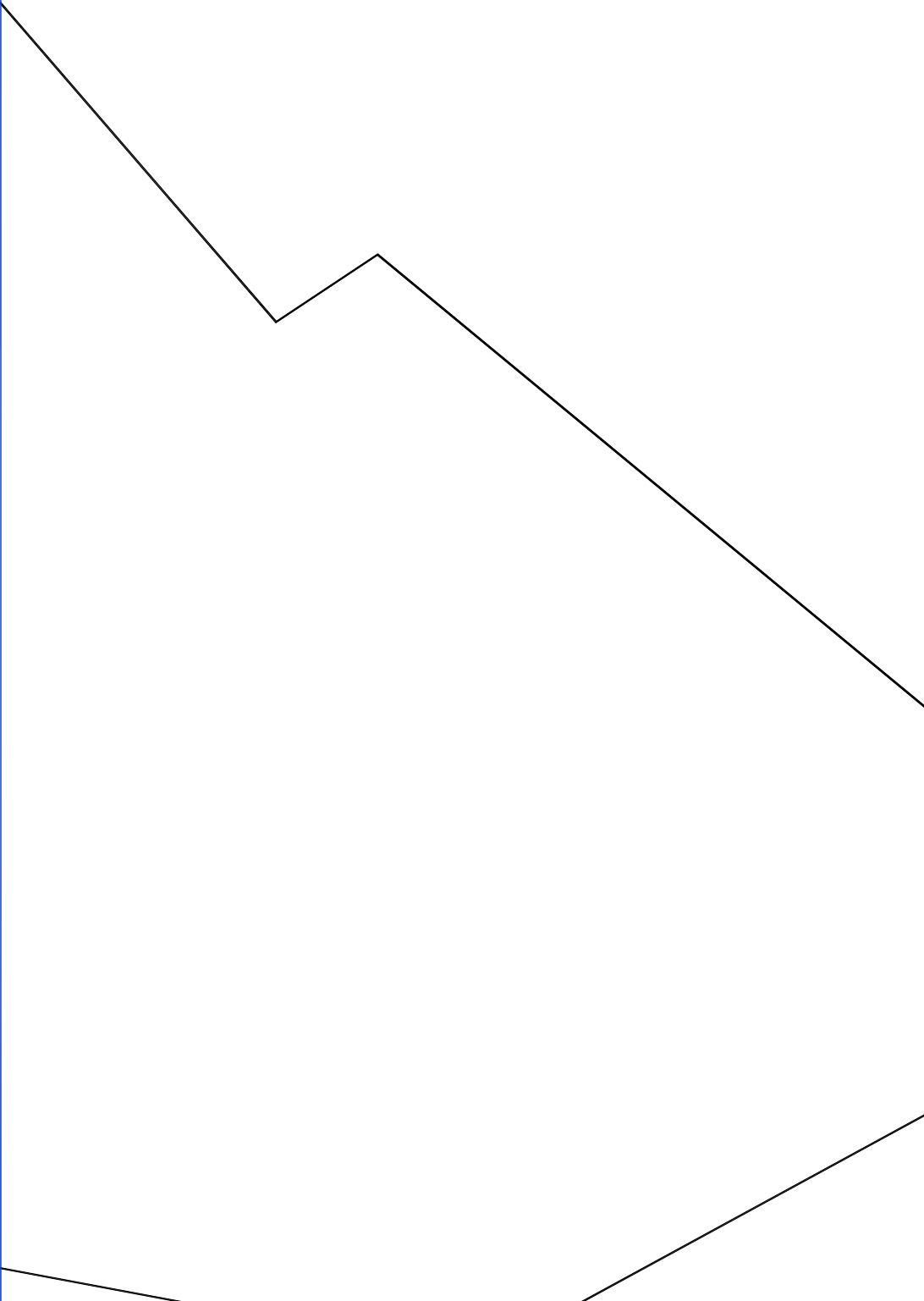

P15

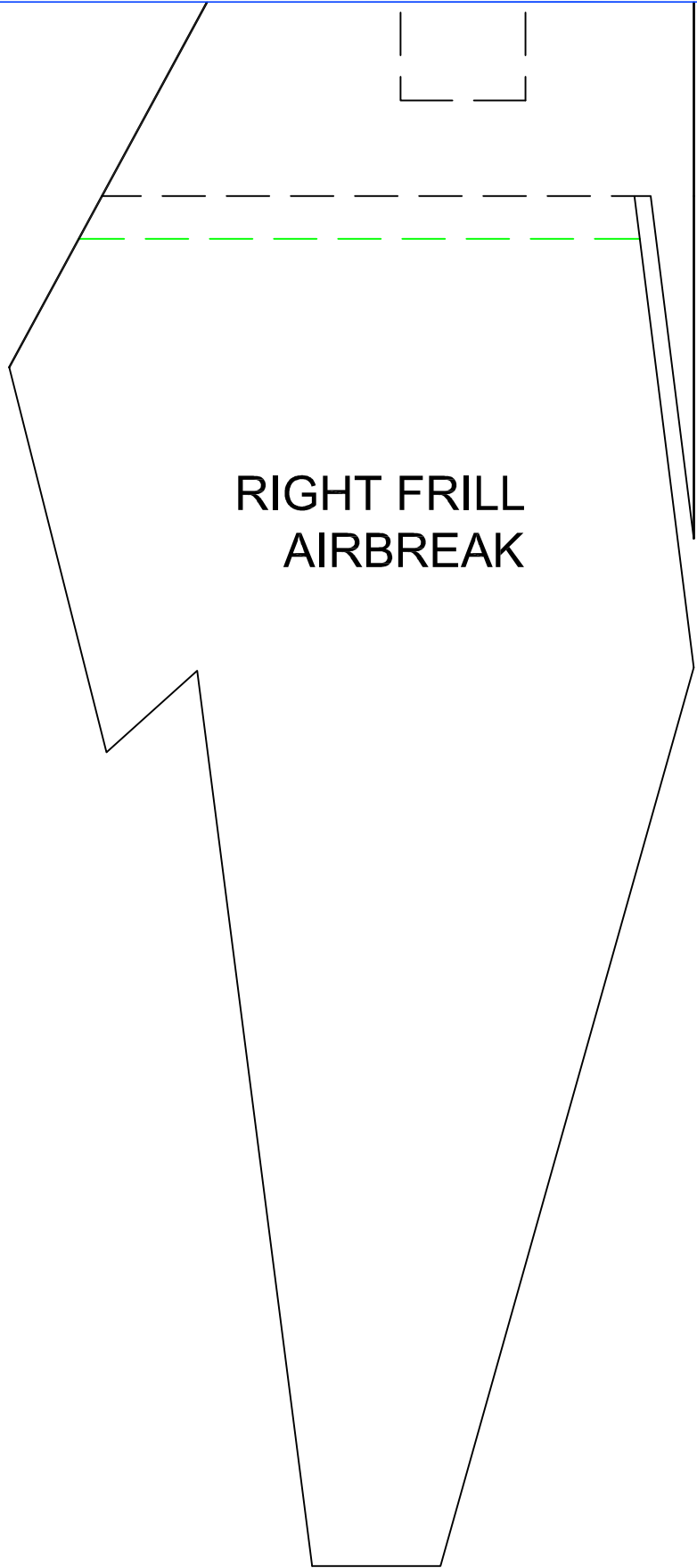

P16

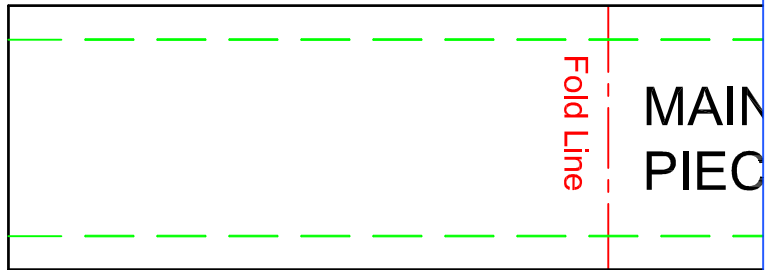
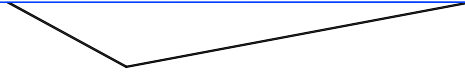

P17

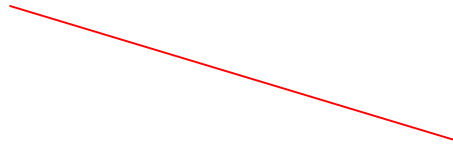

Exact Place
Vertical Sta

Elevron

FUSELAGE TOP
E

Fold Line

Fold Line

Fold Line

P18

ment of
blizers

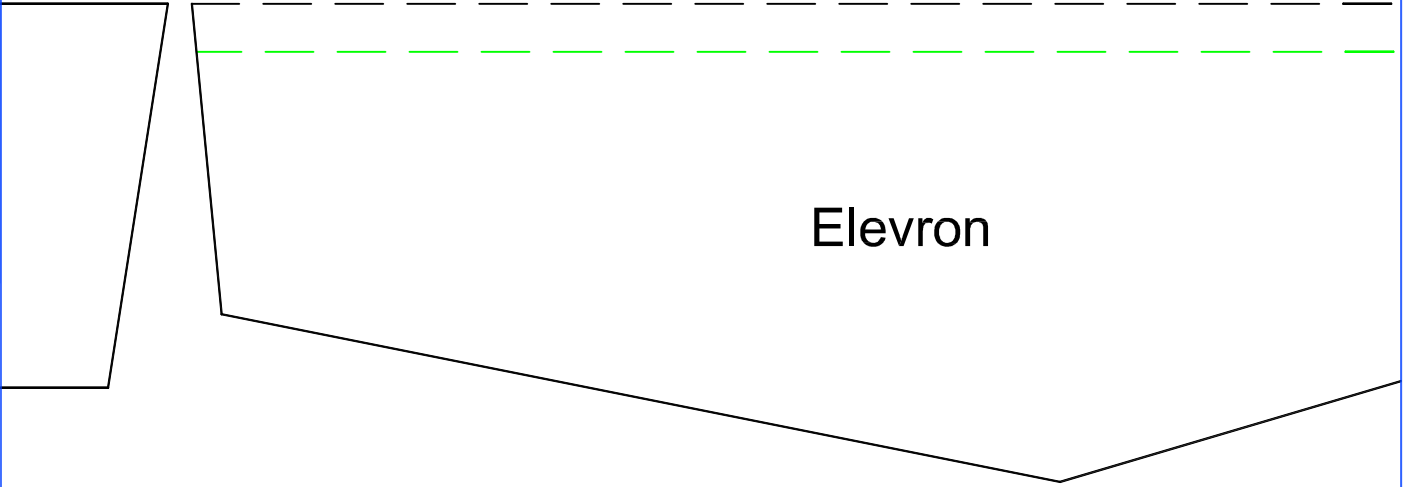
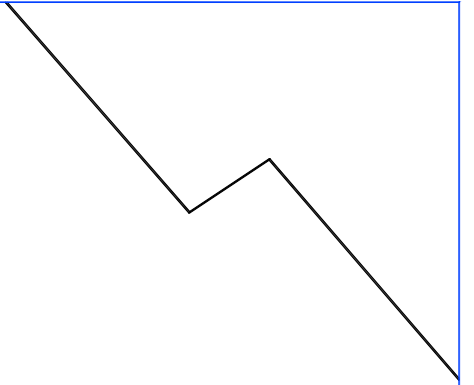

Elevron

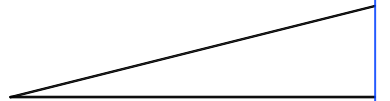
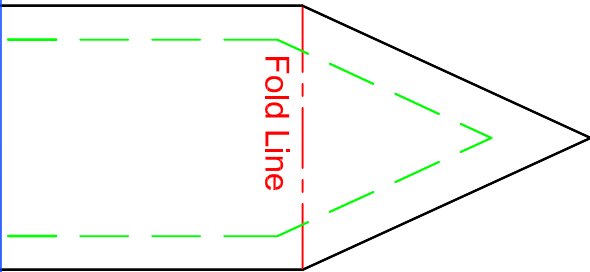

P 19

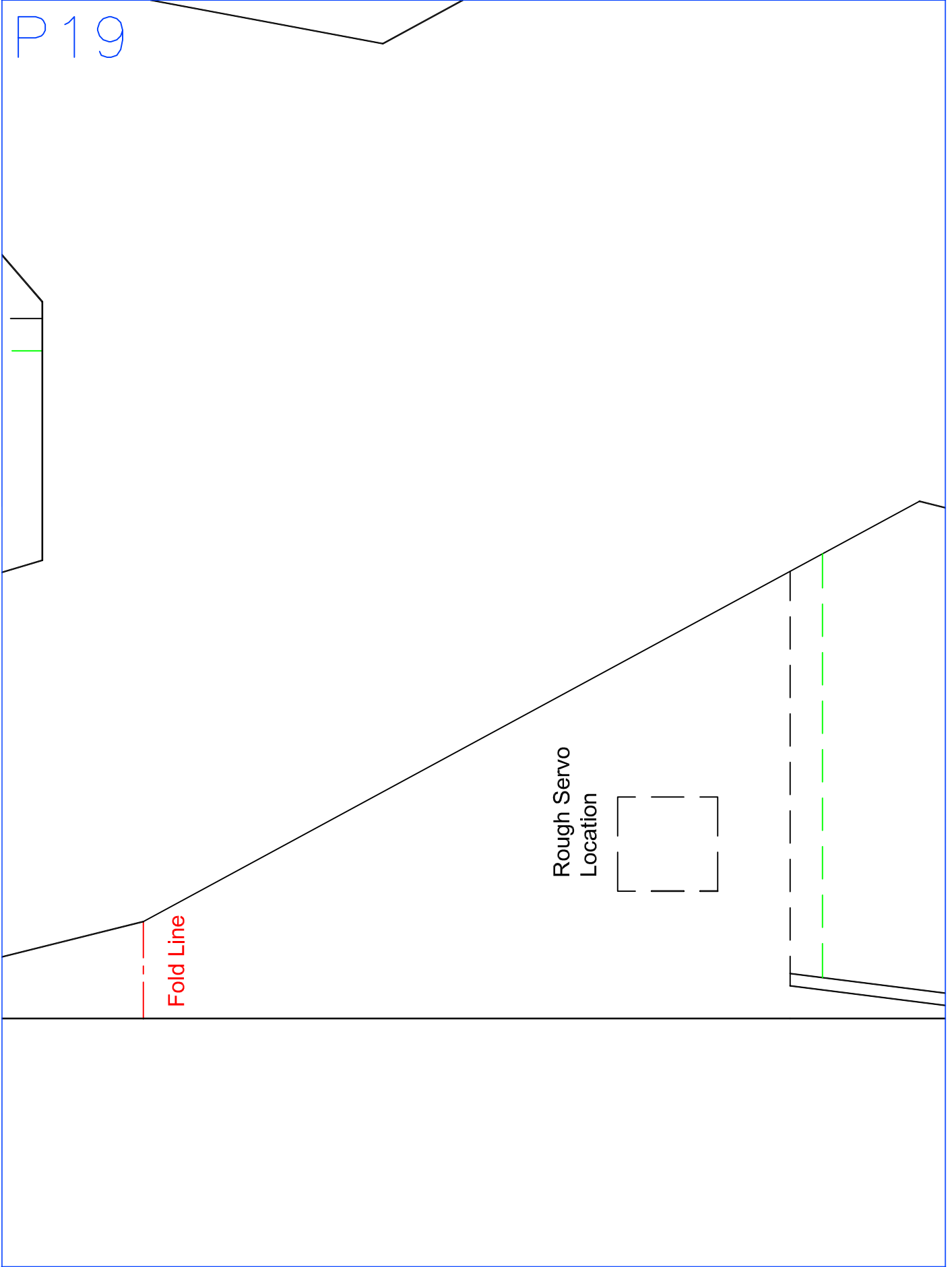

P20

LEFT FRILL
AIRBREAK

